

Leeds Institute of Molecular Medicine, University of Leeds

# Research Protocol

Final version 3.1 dated 12 January 2012

---

**Study Short Title: The seAFood (Systematic Evaluation of Aspirin and Fish Oil) Polyp Prevention Trial**

**Study Full Title: A randomised controlled trial of eicosapentaenoic acid (EPA) and/or aspirin for colorectal adenoma (or polyp) prevention during colonoscopic surveillance in the NHS Bowel Cancer Screening Programme: The seAFood (Systematic Evaluation of Aspirin and Fish Oil) Polyp Prevention Trial**

**Sponsor Name: University of Leeds**

**Sponsor Number: GA10/9312**

**EudraCT Number: 2010-020943-10**

**ISRCTN05926847**

---

**Chief Investigator**

**Professor Mark Hull  
Professor of Molecular Gastroenterology  
Leeds Institute of Molecular Medicine  
Wellcome Trust Brenner Building  
St James's University Hospital  
Leeds, LS9 7TF  
Tel: 0113 343 8650  
Email: M.A.Hull@leeds.ac.uk**

---

## SIGNATURES PAGE

The seAFOod Trial, Final version 3.1, dated 12 January 2012  
Written and approved by the following:



Professor Mark Hull  
Chief Investigator

16 Jan 2012

Date

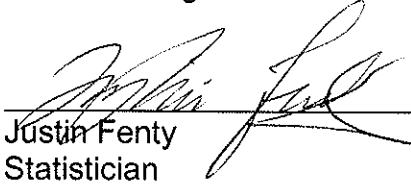

Justin Fenty  
Statistician

Date

16/01/12

---

### Principal Investigator Declaration

I confirm I have read and understood this protocol and I agree to conduct the study in accordance with the protocol.

Principal Investigator: (name) \_\_\_\_\_

Centre name: \_\_\_\_\_

Signature: \_\_\_\_\_

Date: \_\_\_\_\_

---

## **KEY CONTACTS**

### **Chief Investigator:**

**Professor Mark Hull  
Professor of Molecular Gastroenterology  
Leeds Institute of Molecular Medicine  
Wellcome Trust Brenner Building  
St James's University Hospital  
Leeds, LS9 7TF  
Tel: 0113 343 8650  
Email: M.A.Hull@leeds.ac.uk**

### **Trial Statistician:**

**Justin Fenty  
Nottingham Clinical Trials Unit  
Nottingham Health Science Partners  
C Floor, South Block  
Queens Medical Centre  
Nottingham, NG7 2UH  
Tel: 0115 8844921**

### **Trial Pharmacist**

**Gill Bumphrey  
Nottingham Clinical Trials Unit  
Nottingham Health Science Partners  
C Floor, South Block  
Queens Medical Centre  
Nottingham, NG7 2UH  
Tel: 0115 8844928**

### **Trial Manager:**

**Anna Sandell  
Nottingham Clinical Trials Unit  
Nottingham Health Science Partners  
C Floor, South Block  
Queens Medical Centre  
Nottingham, NG7 2UH  
Tel: 0115 8844931**

## ABBREVIATIONS

Abbreviation	Description
AA	arachidonic acid
AE	Adverse Event
ADR	Adverse Drug Reaction
BCSP	NHS Bowel Cancer Screening Programme
BSG	British Society of Gastroenterology
CI	Chief Investigator
Co-I	Co-investigator
COX	cyclooxygenase
CRC	colorectal cancer
crd	clinically relevant difference
CRF	Case Report Form
CTU	Clinical Trials Unit
DHA	docosahexaenoic acid
DMC	Data Monitoring Committee
DSUR	Development Safety Update Reports
ECMC	Experimental Cancer Medicine Centre
EPA	eicosapentaenoic acid
EPA-FFA	EPA in the free fatty acid form
FAP	familial adenomatous polyposis
FFA	free fatty acid
FFQ	Food Frequency Questionnaire
FOBt	faecal occult blood test
GCLP	Good Clinical Laboratory Practice
GCP	Good Clinical Practice
IB	Investigator Brochure
IMP	Investigational Medicinal Product
LC/MSx2	liquid chromatography-tandem mass spectrometry
MHRA	Medicines and Healthcare products Regulatory Agency
NCRI	National Cancer Research Institute
NSAID	non-steroidal anti-inflammatory drug
OTC	'over-the-counter'
PI	Principal Investigator
PIL	Patient Information Leaflet
PUFA	polyunsaturated fatty acid
R&D	Research & Development
RCT	Randomised Controlled Trial
REC	Research Ethics Committee
RN	Research Nurse
RSA	Research Sponsorship Agreement
SAE	Serious Adverse Event
SPC	Summary of Product Characteristics
SSP	Specialist Screening Practitioner
TSC	Trial Steering Committee
QA	Quality Assurance

## STUDY SUMMARY

GENERAL INFORMATION	
Short Title	The seAFOod ( <u>S</u> ystematic <u>E</u> valuation of <u>A</u> spirin and <u>F</u> ish <u>O</u> il) polyp prevention trial
Full Title	A randomised controlled trial of eicosapentaenoic acid (EPA) and/or aspirin for colorectal adenoma (or polyp) prevention during colonoscopic surveillance in the NHS Bowel Cancer Screening Programme: The seAFOod ( <u>S</u> ystematic <u>E</u> valuation of <u>A</u> spirin and <u>F</u> ish <u>O</u> il) Polyp Prevention Trial
Sponsor	University of Leeds
Sponsor ID	GA10/9312
EudraCT No.	2010-020943-10
REC No.	10/H0405/90
ISCRTN	05926847
Chief Investigator	Professor Mark Hull
Co-ordinating Centre	Nottingham Clinical Trials Unit
National / International	National
TRIAL INFORMATION	
Phase	3
Indication	Secondary colorectal adenoma prevention
Design	A randomised, double-blind, placebo-controlled 2 x 2 factorial study.
Primary Objectives	To determine whether the naturally-occurring omega ( $\omega$ )-3 polyunsaturated fatty acid eicosapentaenoic acid (EPA) prevents colorectal adenomas, either alone or in combination with aspirin.
Secondary Objectives	To assess the tolerability and safety of EPA in the free fatty acid form (EPA-FFA) alone, and in combination with aspirin, in elderly (60-75 years) subjects.
TRIAL TIMELINES	
Expected start date	01 November 2010
Participant enrolment phase	07 Oct 2011
Follow-up duration	There is no active follow-up stage of the Trial after surveillance colonoscopy but participant consent will be obtained to access anonymised BCSP data on colonoscopic outcomes during BSCP surveillance up to six years after involvement in the Trial.
End of Trial Definition	The last participant's last visit

Expected completion date	31 October 2014
<b>TRIAL SUBJECT INFORMATION</b>	
Number of trial participants	904
Age group of trial participants	60-73 years old
Inclusion criteria	60-73 year-old BCSP patients who have been identified as <b>'high risk' (5 or more small adenomas or ≥ 3 adenomas with at least one being ≥ 10 mm in diameter)</b> after a single clearance screening colonoscopy
Exclusion criteria	<ul style="list-style-type: none"> <li>• Need for repeat colonoscopy or flexible sigmoidoscopy to check for adenoma excision within a 3 month window</li> <li>• Malignant change in an adenoma requiring Colorectal Cancer Multi-disciplinary Team management</li> <li>• Regular (&gt;3 doses per week) prescribed or 'over-the-counter' (OTC) aspirin or regular (&gt;3 doses per week) prescribed or OTC non-aspirin non-steroidal anti-inflammatory drug (NSAID) use*</li> <li>• Aspirin intolerance or hypersensitivity, including aspirin-sensitive asthma</li> <li>• Active peptic ulcer disease within 3 months or previous peptic ulcer (not on proton pump inhibitor prophylaxis)</li> <li>• Fish or seafood allergy</li> <li>• Current or planned regular (&gt;3 doses per week) use of fish oil supplements*</li> <li>• Known clinical diagnosis or gene carrier of a hereditary colorectal cancer (CRC) predisposition (familial adenomatous polyposis (FAP), hereditary non-polyposis colorectal cancer (HNPCC))</li> <li>• Previous or newly diagnosed inflammatory bowel disease</li> <li>• Previous or planned colorectal resection</li> <li>• Known bleeding diathesis or concomitant warfarin therapy or use of any other anti-coagulant or anti-platelet agent (eg. Clopidogrel)</li> <li>• Severe liver impairment</li> <li>• Severe renal failure (creatinine clearance &lt;10 ml/min)</li> <li>• Current methotrexate use at a weekly dose of 15 mg or more</li> <li>• Inability to comply with study procedures and agents</li> <li>• Serious medical illness interfering with study participation</li> <li>• Participant taking part in another interventional clinical trial</li> <li>• Failure to give written informed consent</li> </ul> <p style="color: red; margin-top: 10px;">* not an exclusion if self-prescribed and not recommended by a Doctor and willing to stop for the duration of the Trial</p>

**INVESTIGATIONAL MEDICINAL PRODUCT**

IMP name(s)	Gastro-resistant EPA-FFA 2g daily Enteric-coated aspirin 300mg daily Placebo for EPA-FFA Placebo for aspirin
Duration of IMP Treatment	From the day after dispensing at visit 1 to the day before surveillance colonoscopy approximately 12 months after screening colonoscopy
IMP Supplier(s)	SLA Pharma AG will supply gastro-resistant EPA-FFA and placebo for EPA-FFA Bayer-Schering Pharma AG will supply enteric-coated aspirin and placebo for aspirin
Non IMP name(s)	N/A

## TABLE OF CONTENTS

Signatures Page .....	2
Key contacts .....	3
AbbreviaTions.....	4
Study Summary .....	5
Table of Contents .....	8
1. Introduction .....	11
1.1 Background.....	11
1.2 Investigational Medicinal Product.....	15
1.2.1: Investigator Brochure (IB) Updates.....	15
1.2.2: Summary of Product Characteristics (SPC).....	15
1.2.3: Investigational Medicinal Products (IMPs) .....	15
1.2.4: Non IMP(s).....	15
1.3 Rationale for the Proposed Study.....	15
1.4 Good Clinical Practice (GCP) and Regulatory Compliance .....	16
2. Trial Objectives .....	17
3. Trial Design.....	17
3.1 Endpoints .....	17
3.1.1: Primary Endpoint .....	17
3.1.2: Secondary Endpoints.....	17
3.1.3: Exploratory Endpoints.....	17
3.2 Stopping rules and discontinuation.....	18
4. Trial Participant Selection .....	18
4.1 Eligibility Criteria.....	18
4.1.1: Inclusion Criteria .....	18
4.1.2: Exclusion Criteria.....	18
4.2 Recruitment, Consent and Randomisation Processes .....	19
4.2.1: Recruitment .....	19
4.2.2: Consent .....	19
4.2.3: Randomisation.....	19
4.2.4: Un-blinding.....	20
4.2.5: Participants who Withdraw .....	21
4.2.6: Managing / replacing participants who withdraw from the trial early .....	21
4.2.7: Definition for the End of Trial .....	21
5. Trial Drug Treatment.....	21
5.1 General information on the products (trial drugs) to be used .....	21
5.2 Frequency and duration of the trial drugs.....	22

5.3 Administration / handling of the trial drugs .....	22
5.3.1 Packaging and labelling.....	22
5.3.2 Storage, dispensing and return.....	22
5.3.3 Known Side Effects.....	23
5.4 Concomitant Medications and Treatment.....	23
5.5 Special warnings and precaution for use with other concomitant medications .....	24
5.6 Contra-indicated medication.....	24
5.7 Dose Modifications .....	24
5.8 Drug Supply .....	25
5.9 Management of trial treatment overdose.....	25
5.10 Discontinuation of Treatment .....	25
6.Trial Schedule.....	26
6.1 Visit by visit schedule (see Appendices A & B) .....	26
Trial information provided (T= -2 weeks) .....	26
Consent and Randomisation Visit 1 (7-14 days after the clearance BCSP colonoscopy, T= 0 weeks) .....	26
Telephone call (T= 2 weeks).....	26
Telephone call (T= 12 weeks).....	26
Out-patient Visit 4 (T= 25 weeks) .....	26
Telephone call (T= 38 weeks).....	26
Exit colonoscopy Visit 3 (T= 50 weeks) .....	27
Routine post-colonoscopy Visit 4 (T= 52 weeks) .....	27
The opportunity for long-term follow-up in the BCSP.....	27
6.2 Summary trial schedule.....	27
6.3 Laboratory mechanistic and biomarker studies .....	27
6.3.1 Transport and Storage of the Samples .....	27
6.3.2 Laboratory Analyses .....	28
7. Pharmacovigilance.....	28
7.1 Defining Adverse Events .....	28
7.2 Defining Serious Adverse Event.....	29
7.3 Defining Suspected Unexpected Serious Adverse Reactions (SUSARs).....	30
7.4 Reporting AEs .....	30
7.5 Reporting SAEs.....	30
7.6 Reporting SUSARs.....	30
7.7 Pregnancy .....	31
7.8 Annual Safety Report (ASR) .....	31
7.9 End of Trial Report.....	31
8. Data Collection, Source Data and Confidentiality .....	31
8.1 General .....	31

8.2 Archiving .....	32
9. Statistical Considerations.....	32
9.1 Sample Size / Power Calculations.....	32
9.2 Statistical Analysis.....	33
9.2.1 Methods to be used .....	33
9.2.2 Assessment of efficacy .....	34
9.2.3 Assessment of Safety .....	34
9.2.4 Analysis populations .....	35
9.2.5 Missing data.....	35
10. Data Monitoring .....	36
10.1 Data Monitoring.....	36
10.2 Quality Assurance .....	36
10.3 Trial Steering Committee.....	36
10.4 Data Monitoring Committee.....	37
11. Ethical Considerations .....	38
12. Statement of Indemnity .....	38
13. Publication Policy.....	38
14. Trial Organisational Structure .....	39
15. References .....	40
16. Appendices .....	42
Appendix A: Visit table .....	42
Appendix B: Trial Schema.....	43
Appendix C: Known side effects of the Trial drugs.....	44
Appendix D: The seAFOod Polyp Prevention Trial protocol for laboratory studies .....	47
Appendix E: Details of previous amendments:.....	56

# 1. INTRODUCTION

## 1.1 Background

### Colorectal cancer chemoprevention

#### *Colorectal cancer prevention strategies*

The scientific and clinical rationale for prevention of colorectal cancer (CRC) is firmly established<sup>1</sup>. CRC prevention strategies currently used, or under evaluation, include population screening, endoscopic surveillance of high-risk groups, chemoprevention (the use of drugs, vitamins or other food supplements), and health education leading to beneficial lifestyle modification<sup>1</sup>.

#### *Why bother with chemoprevention of CRC?*

The long natural history of human 'sporadic' colorectal carcinogenesis, during which tumour initiation and benign adenoma (or polyp) growth precede transformation into a clinically apparent malignant adenocarcinoma (or cancer) over a number of years, has been the basis for CRC prevention strategies aimed at detection and removal of asymptomatic colorectal adenomas in healthy individuals (either directly by colonoscopy- or flexible sigmoidoscopy-based screening, or indirectly via colonoscopy prompted by faecal occult blood testing [FOBT]). However, recent assessments of the effectiveness of colorectal adenoma removal as the sole method for reducing CRC incidence have demonstrated that CRC remains a significant problem in screened populations<sup>2-5</sup>. For example, no reduction in CRC incidence was seen during 7 years follow-up after once-only flexible sigmoidoscopy in Norway<sup>2</sup> and the UK once-only flexible sigmoidoscopy Trial demonstrated only a 23% reduction in CRC incidence in the intervention group compared with controls at 10 years<sup>4</sup>. Moreover, 18 years follow-up of the Minnesota FOBT trial (in which the colonoscopy rate was nearly 40%) found only a 20% reduction in CRC incidence<sup>5</sup>. It is also clear that CRC occurs even in patients under close colonoscopic surveillance (1.7 CRCs/1000 person-years)<sup>6</sup>. **Therefore, there is still an unmet clinical need for safe and effective CRC chemoprevention, in combination with existing screening and surveillance programmes.**

#### *Candidate CRC chemoprevention agents*

A recent review has summarised the existing literature on several potential CRC chemoprevention agents including non-steroidal anti-inflammatory drugs (NSAIDs), hormone replacement therapy and micro-nutrients e.g. folic acid, vitamin D<sup>7</sup>. The largest body of evidence supports the use of the NSAID aspirin for CRC chemoprevention<sup>8</sup>. Observational and RCT data suggest that use of aspirin at doses greater than 300 mg daily for more than 5 years is effective for primary prevention of 'sporadic' CRC<sup>9</sup>. Indeed, in the long-term follow-up of two British aspirin Trials there was an overall 40% reduction in CRC incidence in participants randomised to 5 years of aspirin at doses greater than 300mg daily, which increased to a 74% reduction in fully compliant participants at 10-14 years<sup>9</sup>. Furthermore, a random-effects meta-analysis of the four previous RCTs of aspirin, using colonoscopic adenoma recurrence as a surrogate marker of CRC recurrence, reported a pooled risk ratio for an 'advanced' colorectal neoplasm or any adenoma in aspirin users of 0.72 (95% confidence interval [CI] 0.57-0.90) and 0.83 (95% CI 0.72-0.96) respectively, an effect which was already apparent in the first year of these studies (RR 0.62 [95% CI 0.48-0.81])<sup>10</sup>.

However, aspirin has not yet been advocated for primary or secondary CRC chemoprevention due to continuing uncertainty about the optimal daily dose (different trials have reported efficacy of either high- (>300 mg) or low-dose (<100 mg) aspirin<sup>10</sup>) and the

absence of a clearly defined at-risk population, in whom benefit would outweigh the small risk of gastro-intestinal and intra-cerebral bleeding associated with aspirin<sup>8</sup>.

Selective cyclooxygenase (COX)-2 inhibitors were developed as anti-inflammatory drugs with little or no gastro-intestinal toxicity compared with traditional NSAIDs (which are non-selective COX-1 and COX-2 inhibitors)<sup>7</sup>. Evaluation of the CRC chemopreventative efficacy of the selective COX-2 inhibitors celecoxib and rofecoxib was prompted by consistent evidence that regular NSAID use is associated with 40-50% decreased CRC risk<sup>6</sup> and the critical role of Cox-2 in animal models of colorectal carcinogenesis<sup>11</sup>. As predicted by the pre-clinical studies, both coxibs had significant chemopreventative efficacy (20-30% reduction in polyp burden or recurrence) in randomised controlled Trials (RCTs) of familial adenomatous polyposis (FAP)<sup>12</sup> and 'sporadic' adenoma patients<sup>7</sup>. However, the unexpected cardiovascular toxicity associated with prolonged selective COX-2 inhibition, which became apparent in the polyp prevention Trials, precludes a role for the coxibs in 'sporadic' CRC chemoprevention<sup>13</sup>.

In summary, despite evidence that selective COX-2 inhibitors and aspirin prevent colorectal adenoma recurrence<sup>7,10</sup> and (in the case of aspirin) CRC incidence<sup>9</sup>, neither class of agent has yet been introduced into clinical practice for 'sporadic' CRC chemoprevention because of concerns about toxicity, uncertainty about the most efficacious dose and the absence of a clearly defined target population.

Combination therapy is widely recognised as a promising strategy for CRC chemoprevention, particularly if the combination of agents has other beneficial effects<sup>14</sup>. The omega ( $\omega$ )-3 polyunsaturated fatty acid eicosapentaenoic acid is an attractive candidate 'natural' CRC chemoprevention agent for evaluation alone, and in combination with aspirin, given that both agents also demonstrate cardiovascular benefits and are already widely prescribed together following myocardial infarction<sup>15</sup>.

### *Omega-3 polyunsaturated fatty acids*

Polyunsaturated fatty acids (PUFAs) are important components of the normal diet. Two classes of PUFAs,  $\omega$ -6 and  $\omega$ -3 PUFAs, are classified as essential in that they cannot be readily synthesised in the human body and so must be obtained from dietary sources<sup>16</sup>. The principal  $\omega$ -3 PUFAs are C20:5 eicosapentaenoic acid (EPA) and C22:6 docosahexaenoic acid (DHA), which are found predominantly in oily, cold-water fish such as mackerel, having entered the food chain following synthesis by plankton<sup>16</sup>. However, in 'western' diets,  $\omega$ -6 PUFAs predominate including C20:4 arachidonic acid (AA), which is the main substrate for the COX enzymes<sup>16</sup>.

### *Anti-CRC activity of $\omega$ -3 PUFAs*

There is strong pre-clinical evidence that  $\omega$ -3 PUFAs have anti-CRC activity, which is reviewed by Calviello *et al*<sup>17</sup>. However, systematic review of epidemiological studies has not demonstrated unequivocal benefit from dietary  $\omega$ -3 PUFA intake on CRC risk, with both 'positive' and 'negative' observational reports<sup>18</sup>. This may be related to the methodological difficulties of measuring  $\omega$ -3 PUFA or fish intake in populations. Alternatively,  $\omega$ -3 PUFA exposure may not be sufficient for consistent anti-CRC activity in individuals consuming moderate amounts of fish (a portion of oily fish 2-3 times per week only provides the equivalent of approximately 500 mg per day of EPA and DHA combined). Omega-3 PUFA intake can be increased by 'over-the-counter' fish oil supplements but many of these have a range of minor, troublesome side-effects (e.g. halitosis).

### *EPA as a CRC chemoprevention agent*

A 500 mg gastro-resistant capsule formulation of EPA as the free fatty acid (FFA) is now available for administration of large amounts of EPA, up to 2g daily. EPA is released

from the capsules and absorbed maximally in the small intestine, thereby minimising gastrointestinal side-effects. EPA as the free fatty acid (EPA-FFA) is significantly better absorbed than EPA in the usual ethyl ester or triglyceride forms<sup>19</sup>.

EPA-FFA (2.5-5% [w/w] in chow) has recently been demonstrated to reduce intestinal adenoma multiplicity by 79% in the *Apc<sup>Min/+</sup>* mouse model of FAP<sup>20</sup>. Preliminary evidence that EPA-FFA has chemopreventative efficacy in humans was provided by two separate Phase II studies of EPA-FFA 2g daily in patients with previous colorectal adenoma, which demonstrated a significant reduction in rectal epithelial cell mitosis frequency (not observed with a 1g daily dose), which was associated with a five-fold increase in rectal mucosal EPA content<sup>21-22</sup>. These studies led to a Phase III double-blind RCT of the effect of treatment with EPA-FFA 2g daily for 6 months on rectal polyposis in patients with FAP (n=58), which we have recently published<sup>23</sup>. This trial has provided the first definitive evidence of chemopreventative efficacy of EPA in humans with a net decrease in adenoma number and cumulative adenoma size of 22.4% and 29.8% respectively between the EPA and placebo arms<sup>23</sup>. The percentage reduction in polyp burden was similar to the anti-neoplastic activity previously observed in FAP patients treated with celecoxib<sup>12</sup>, a drug which was subsequently demonstrated to prevent 'sporadic' colorectal adenomas<sup>7</sup>.

#### *Mechanisms of the anti-neoplastic activity of EPA and aspirin*

The precise mechanism(s) by which EPA and aspirin have anti-CRC activity are not fully understood<sup>8, 17</sup>. However, it is currently accepted that, even though these agents are likely to act via both COX-dependent and -independent mechanisms, modulation of COX activity plays an important role in their anti-neoplastic effects. EPA and aspirin are both potent inhibitors of cyclooxygenase (COX)-1 but they alter COX-2 activity in different ways leading to production of different bioactive lipid mediators, including PGE<sub>3</sub> (EPA) and 15R-HETE (aspirin)<sup>16</sup>. There is some evidence that PGE<sub>3</sub> (unlike PGE<sub>2</sub>) has anti-tumorigenic activity<sup>24</sup> and it is known that aspirin-triggered lipoxins derived from 15R-HETE have anti-angiogenic properties<sup>25</sup>.

Aspirin irreversibly acetylates the COX enzymes<sup>26</sup>. When EPA acts as a substrate for aspirin-acetylated COX-2, it leads to synthesis of 18R-hydroxyeicosapentaenoic acid (18R-HEPE), which can be converted in a 5-LOX-dependent manner to resolvin (Rv) E1<sup>26-27</sup>. Resolvin E1 has potent anti-inflammatory activity<sup>27</sup> but it is currently not known whether RvE1 has direct anti-neoplastic activity.

Therefore, there is a biochemical basis for a potential interaction between EPA and aspirin. However, the available clinical evidence suggests that the cardiovascular effects of EPA and aspirin are simply additive based on the accumulated evidence of extensive use of dual therapy in cardiology patients<sup>15</sup> and the effects of the two agents in *ex vivo* human platelet aggregation studies<sup>28-29</sup>.

#### *Predictive biomarkers of anti-neoplastic activity of EPA and aspirin*

Membrane and plasma EPA levels are established biomarkers of dietary  $\omega$ -3 PUFA exposure in cancer epidemiological studies<sup>30</sup>. More recently, rectal mucosal EPA content was measured in the RCT of EPA-FFA in FAP patients<sup>23</sup>. Incorporation of EPA into rectal mucosa after oral EPA administration confirmed compliance and the bioavailability of EPA in the target tissue. However, there was no relationship between the individual percentage EPA mucosal content and the reduction in rectal polyp number (unpublished data). Therefore, there is a need for novel biomarkers based on the mechanism of action of EPA, which may predict individual therapeutic response.

The lipid products of COX-dependent metabolism after EPA and/or aspirin treatment noted above can be measured by liquid chromatography-tandem mass spectrometry (LC/MSx2)<sup>31</sup>. For example, measurement of urinary levels of the stable

product of PGE<sub>2</sub> catabolism, termed PGE-M, is established in the Institute of Cancer Therapeutics, University of Bradford. Moreover, we have detected 18R-HEPE in ng/ml quantities in plasma after aspirin (300mg) and EPA-FFA (1g) ingestion (unpublished data).

Recently, the pattern of COX-2 expression in the index adenoma has been demonstrated to predict the preventative efficacy of aspirin in the APACC polyp prevention trial<sup>32</sup>. This preliminary finding suggests that potential predictive biomarkers in polypectomy specimens, such as COX-2 and ChemR23 (the cell-surface RvE1 receptor<sup>27</sup>), should be evaluated in a large prospective RCT.

## **Risks and benefits**

### *Safety and tolerability of EPA and aspirin*

Aspirin and  $\omega$ -3 PUFAs are already used widely in an elderly patient population relevant to 'sporadic' CRC prevention for prophylaxis following myocardial infarction (aspirin and  $\omega$ -3 PUFAs), hypertriglyceridaemia ( $\omega$ -3 PUFAs) and stroke (aspirin)<sup>15</sup>.

Safety and tolerability of aspirin (82-325mg daily) in polyp prevention trials using individuals with similar characteristics to our proposed seAFood Trial population has been excellent<sup>7, 10</sup>.

To date, gastro-resistant EPA-FFA 2g daily has been given to 105 patients for 6 months in clinical studies. Tolerability has been excellent with no unpleasant taste and smell sensations. In our RCT in FAP patients, there was no significant excess of adverse events (AEs) in the EPA-FFA group compared with placebo, with only one withdrawal in the EPA-FFA group due to nausea and epigastric pain<sup>23</sup>. In two Phase II studies of colorectal adenoma patients with similar characteristics to seAFood Trial participants (mean age 58 years), withdrawal due to an AE (10%) and minor gastrointestinal AEs (including dyspepsia [4%] and diarrhoea [14%]) in individuals taking EPA-FFA were higher (but not significantly so) than in the no treatment<sup>21</sup> or placebo arms<sup>22</sup>. In the latter study, the slight excess of gastrointestinal AEs observed in the EPA-FFA 2g daily group was not apparent in those taking 1g EPA-FFA daily<sup>22</sup>. In the former study, diarrhoea in three patients resolved after dose de-escalation to 1g EPA-FFA daily<sup>21</sup>.

Although aspirin and  $\omega$ -3 PUFAs share anti-platelet activity and prolong bleeding time, excess bleeding episodes with their combined use have not been observed in cardiological practice<sup>33</sup>. There have been no excess bleeding episodes during >7000 patient-years of the ongoing ASCEND 2 x 2 factorial trial of aspirin and an  $\omega$ -3 PUFA preparation (Omacor) in patients with type II diabetes co-ordinated by the Oxford CTU (personal communication).

### *Potential cardiovascular benefits of combination therapy in addition to CRC chemopreventative efficacy*

Colorectal carcinogenesis and atherosclerosis share common pathophysiological mechanisms and clinical risk factors<sup>34</sup>. As a consequence, ischaemic heart disease and stroke are common in elderly populations with colorectal neoplasia<sup>34</sup>. Therefore, an attractive feature of a CRC chemoprevention strategy featuring EPA and/or aspirin is the potential for additional vascular benefit in elderly colorectal adenoma 'formers' at simultaneous risk of occlusive vascular events<sup>8,15</sup>. This aspect of chemoprevention with EPA alone, or in combination with aspirin, will be addressed in a Health Technology Assessment (HTA)-funded 'effectiveness' study following our proposed CRC chemoprevention efficacy trial.

## 1.2 Investigational Medicinal Product

### 1.2.1: Investigator Brochure (IB) Updates

An Investigator Brochure for the gastro-resistant formulation of EPA-FFA will be used and provided by SLA Pharma AG. The IB is reviewed annually.

### 1.2.2: Summary of Product Characteristics (SPC)

The SPC for enteric-coated aspirin made by Bayer-Schering Pharma AG will be used. The drug will be used at a licensed dose.

### 1.2.3: Investigational Medicinal Products (IMPs)

The Investigational Medicinal Products to be used in this Trial are Gastro-resistant eicosapentaenoic acid in free fatty acid form (EPA-FFA), enteric-coated aspirin and their identical placebos. SLA Pharma AG will manufacture EPA-FFA capsules and its identical placebo. Aspirin and its identical placebo will be manufactured by Bayer-Schering Pharma AG.

### 1.2.4: Non IMP(s)

The Trial will not use non-IMPs

## 1.3 Rationale for the Proposed Study

The adenoma (or polyp), particularly the 'advanced' lesion ( $\geq 10$  mm diameter, tubulo-villous/villous histology or high-grade dysplasia), is an established surrogate biomarker of CRC risk and has been used consistently as a primary colonoscopic endpoint in multiple short-term (up to 3 years) CRC chemoprevention trials<sup>7,10</sup>.

The NHS Bowel Cancer Screening Programme (BCSP) began in England in July 2006 (see <http://www.cancerscreening.nhs.uk/bowel/index.html>). **This National Screening Programme now provides a superb opportunity to identify large numbers of patients who have had polyps removed and have been entered into a colonoscopic surveillance programme according to strict quality-assured protocols.**

*The NHS Bowel Cancer Screening Programme as the setting for a polyp prevention RCT*

All individuals aged between 60-75 years (and those who are older and 'opt-in') are invited to submit a FOBt by post every 2 years (approximately 50% 'take-up'). Those with a positive FOBt (1.8%) are offered a colonoscopy (approximately 85% 'take-up'). By March 2009 (after 2 million FOBt invitations), 17,518 BCSP colonoscopies have been undertaken leading to a diagnosis of CRC in 10.1%. Individuals who have more than 2 small ( $< 10$  mm) adenomas, or at least one adenoma  $\geq 10$  mm in diameter, detected and removed then undergo colonoscopic surveillance in the BCSP according to British Society of Gastroenterology (BSG) Guidelines<sup>35</sup>. Patients with 5 or more small adenomas (or with greater than or equal to 3 adenomas with at least one being  $\geq 10$  mm in diameter) are defined as 'high risk', which prompts a surveillance procedure one year after index colonoscopy. Nationally, the overall adenoma detection rate is 42.9% with the 'high risk' group representing 9.8% of all colonoscopies (Personal communication, National BCSP Evaluation Group). Detailed analysis of 865 index colonoscopies performed in two 'first-wave' BCSP Centres (South of Tyne and Tees) in 12 months (2007-08) has demonstrated that 97 (11.2%) procedures led to 'high risk' stratification. Data available for 65 of these 'high risk' patients who underwent surveillance colonoscopy at one year have demonstrated an adenoma recurrence rate of 66.2%.

### *Methodological advantages of using a 'high risk' patient cohort in the BCSP*

Previous polyp prevention trials have recruited patients who are roughly equivalent to 'intermediate risk' patients in the BCSP (3-4 adenomas detected or at least one adenoma >10 mm in diameter), which had a three-year total adenoma recurrence rate between 25-50% in the placebo arm<sup>7,10</sup>. Recruitment of 'high risk' BCSP patients undergoing surveillance colonoscopy at one year capitalises on a higher adenoma recurrence rate (>60%) at an earlier (one year) time-point, thus providing sample size and trial duration (and hence cost) benefits for trial design.

Strict adherence to protocol-driven screening and surveillance care pathways, as well as careful colonoscopic and histological quality-assurance, also contribute to the BCSP being an ideal setting for a polyp prevention RCT. In addition, the self-selected nature of the patients undergoing screening colonoscopy and the excellent counselling that BCSP participants obtain ensure excellent compliance with the surveillance phase of the BCSP with 99% and 92% attendance for follow-up out-patient clinic review and one year surveillance colonoscopy respectively in the South of Tyne BCSP Centre. In practice, the only 'high risk' patients that have not attended for surveillance colonoscopy are those who have become medically unfit for colonoscopy or who have undergone surgery after screening colonoscopy.

Previous concerns about the use of a one year end-point in polyp prevention trials have been allayed by the observation that adenoma outcomes at one year have consistently mirrored those reported at later time-points<sup>10</sup>.

Another methodological consideration relates to the potential confounding effect of 'missed' adenomas rather than 'new' lesions detected during short-term colonoscopic assessment of 'recurrence'. Preliminary data from the South of Tyne and Tees BCSP Centres have demonstrated that one or more adenomas (that can be assumed to be 'missed') were detected in 36% of 44 high risk individuals who underwent a check colonoscopy to assess a polypectomy site within three months of the index colonoscopy, compared with a 66.2% adenoma recurrence rate at one year. The large difference in adenoma detection between 3 and 12 months supports the supposition that there is *de novo* adenoma growth over a 12 month period and is mirrored by data from a similar American study<sup>36</sup>. Moreover, 86% of the 'recurrent' adenomas at one year in the South of Tyne and Tees cohort were small, non-advanced adenomas (rather than 'advanced' lesions), which would be expected if the majority of adenomas detected at this time-point represented *de novo* adenoma growth. In practice, short-term colonoscopic 'recurrence', even in expert hands, almost certainly represents a combination of 'new' and 'missed' adenomas. Therefore, chemopreventative efficacy observed in RCTs is likely to be a combination of polyp prevention and regression, a concept that has been readily accepted in 'proof-of-principle' FAP RCTs<sup>12,23</sup>. **Importantly, the reduction in adenoma 'recurrence' in the aspirin polyp prevention RCTs<sup>9</sup> has predicted the longer-term effect of aspirin on CRC incidence<sup>9</sup>, confirming the utility of adenoma recurrence as a surrogate biomarker of CRC risk.**

## **1.4 Good Clinical Practice (GCP) and Regulatory Compliance**

This clinical trial, which involves the use investigational medicinal products (IMPs) has been designed and will be run in accordance with the Principles of GCP and the current regulatory requirements, as detailed in the Medicines for Human Use (Clinical Trials) Regulations 2004 (UK Statutory Instrument (S.I.) 2004 / 1031) and any subsequent amendments of the Clinical Trial Regulations.

## 2. TRIAL OBJECTIVES

### Primary objective

To determine whether the naturally-occurring omega ( $\omega$ )-3 polyunsaturated fatty acid eicosapentaenoic acid (EPA) prevents colorectal adenomas, either alone or in combination with aspirin.

The following primary hypotheses will be tested:

- 1) EPA-FFA 2g daily alone is more effective than placebo for reduction in adenoma recurrence
- 2) EPA-FFA 2g daily and aspirin 300mg daily decrease adenoma recurrence in an additive manner (on a logarithmic scale)

### Secondary objective

To assess the tolerability and safety of EPA in the free fatty acid form (EPA-FFA) alone, and in combination with aspirin, in elderly (60-75 years) subjects.

## 3. TRIAL DESIGN

The seAFOod Polyp Prevention Trial is a randomised, double-blind, placebo-controlled 2 x 2 factorial study. The trial has been designed to integrate fully into the screening and surveillance phases of the NHS Bowel Cancer Screening Programme (BCSP) so that participation will not alter routine clinical practice.

### 3.1 Endpoints

#### 3.1.1: Primary Endpoint

The number of participants with one or more adenomas detected at BCSP surveillance colonoscopy at one year.

#### 3.1.2: Secondary Endpoints

1. The number of participants with one or more 'advanced' ( $\geq 10$  mm diameter, high-grade dysplasia or tubulo-villous/villous histology) adenomas at one year
2. The number of 'advanced' adenomas per participant at BCSP surveillance colonoscopy at one year
3. The total number of adenomas per participant at BCSP surveillance colonoscopy at one year
4. The region of the colorectum (right colon - any part of the colon proximal to the splenic flexure; left colon – the rectum and the colon distal to the splenic flexure) that adenomas are detected at BCSP surveillance colonoscopy at one year
5. The number of 'high risk' participants re-classified as 'intermediate risk' after BCSP surveillance colonoscopy at one year (BCSP risk stratification at one year surveillance colonoscopy follows BSG Guidelines<sup>35</sup> so that any individual that does not continue to fulfil 'high risk' criteria is classified as 'intermediate risk' for further colonoscopic surveillance at three years)
6. Adverse events, including clinically significant bleeding episodes

#### 3.1.3: Exploratory Endpoints

An important component of the seAFOod Polyp Prevention Trial is the measurement of levels of bioactive lipid mediators such as  $\omega$ -3 PUFAs, 18R-HEPE, RvE1 and PGE-M in plasma, urine, erythrocytes and rectal mucosa in order to gain mechanistic insights into the mechanism(s) of action of EPA and aspirin, alone and in combination, as

well as discover predictive biomarkers of EPA and/or aspirin chemoprevention efficacy<sup>40-41</sup>.

Analysis of formalin-fixed, paraffin-embedded polypectomy tissue from the screening colonoscopy will be undertaken in order to characterise potential biomarkers of adenoma recurrence and chemoprevention efficacy.

Details of sample collection, sample storage and laboratory measurements will be described in the seAFOod Polyp Prevention Manual that will be provided to each site.

## 3.2 Stopping rules and discontinuation

No interim analysis for efficacy is planned and hence there are no formal 'stopping rules'. The study may be stopped as a whole because of a Regulatory Authority decision, change in opinion of the REC or overwhelming evidence of efficacy/inefficacy, safety concerns or issues with trial conduct at the discretion of the Sponsor or Trial Steering Committee.

Recruitment at a BCSP Centre may be stopped because of low recruitment, protocol violation or inadequate data recording.

## 4. TRIAL PARTICIPANT SELECTION

### 4.1 Eligibility Criteria

#### 4.1.1: Inclusion Criteria

Recruitment will be restricted to 60-73 year-old NHS Bowel Cancer Screening Programme (BCSP) patients who have been identified as 'high risk' (5 or more small adenomas or  $\geq 3$  adenomas with at least one being  $\geq 10$  mm in diameter) after a single clearance screening colonoscopy.

#### 4.1.2: Exclusion Criteria

- Need for repeat colonoscopy or flexible sigmoidoscopy to check for adenoma excision within a 3 month window
- Malignant change in an adenoma requiring Colorectal Cancer Multi-disciplinary Team management
- Regular (>3 doses per week) prescribed or OTC aspirin or regular (>3 doses per week) prescribed or OTC non-aspirin non-steroidal anti-inflammatory drug (NSAID) use\*
- Aspirin intolerance or hypersensitivity, including aspirin-sensitive asthma
- Active peptic ulcer disease within 3 months or previous peptic ulcer (not on proton pump inhibitor prophylaxis)
- Fish or seafood allergy
- Current or planned regular (>3 doses per week) use of fish oil supplements\*
- Known clinical diagnosis or gene carrier of a hereditary colorectal cancer (CRC) predisposition (familial adenomatous polyposis (FAP), hereditary non-polyposis colorectal cancer (HNPCC))
- Previous or newly diagnosed inflammatory bowel disease
- Previous or planned colorectal resection
- Known bleeding diathesis or concomitant warfarin therapy or use of any other anti-coagulant or anti-platelet agent (eg. Clopidogrel)
- Severe liver impairment
- Severe renal failure (creatinine clearance <10 ml/min)
- Current methotrexate use at a weekly dose of 15 mg or more

- Inability to comply with study procedures and agents
- Serious medical illness interfering with study participation
- Participant taking part in another interventional clinical trial
- Failure to give written informed consent

\*not an exclusion if self-prescribed and not recommended by a doctor and willing to stop for the duration of the Trial

## 4.2 Recruitment, Consent and Randomisation Processes

### 4.2.1: Recruitment

'High risk' BCSP patients are identified immediately at screening colonoscopy on the basis of adenoma number and (endoscopic) size and confirmed later by the histopathology report. All 'high risk' individuals will be given written trial information on discharge by a BCSP Specialist Screening Practitioner (SSP) and this will be clearly documented in the patient's medical notes and on the screening log in the Investigator Site File. The Participant Information Leaflet (PIL) will include detailed information about the rationale, design and personal implications of the study.

Patients will be able to discuss the trial with their family and healthcare professionals before they attend the routine BCSP out-patient visit 7-14 days after screening colonoscopy. During this visit the SSP will ask whether they are willing to take part in the Trial.

A delegated and appropriately qualified SSP(s) or a Research Nurse (RN) can conduct the Trial. In centres where the RN runs the Trial, the SSP will ask the potential participant at the BCSP out-patient visit if they would like to be introduced to the RN to discuss participation in the Trial.

### 4.2.2: Consent

Patients will be formally assessed for eligibility by the SSP or RN at the routine BCSP out-patient visit (when the histological adenoma size is available) 7-14 days after screening colonoscopy. The SSP/RN will usually be the most appropriate person to obtain consent. Therefore, if the patient is eligible, written consent will be sought by the SSP/RN with counter-signature by the local PI or a Co-I the same day or when this is not applicable by the PI or Co-I as defined on the Delegation Log. The local PI or a Co-I will be available to answer any further questions if required. One copy of the Consent Form will be given to the participant, one filed in the Investigator Site File and one filed in the hospital notes together with a note documenting this fact in the participant's medical records. Participants will also be required to sign a further consent form (**SURPLUS TISSUE STORAGE CONSENT FORM**) to consent to the storage of tissue samples. This consent form will only be signed for those participants who have signed point 3 of the main consent form

The right of the participant to refuse consent without giving reasons will be respected. Furthermore, the participant will remain free to withdraw from the study at any time without giving reasons and without prejudicing further management in the BCSP.

### 4.2.3: Randomisation

After written consent has been obtained, the SSP/RN will organise randomisation of the participant according to a simple 2 x 2 factorial design to:

- gastro-resistant EPA-FFA 2g daily by mouth (as 2 x 500mg ALFA™ capsules taken twice daily with food) **or** identical placebo (capric and capryllic acid medium-chain triglycerides)<sup>23</sup>

- enteric-coated aspirin 300mg daily by mouth (as one 300mg tablet taken with food) **or** identical placebo

Placebo Placebo	Placebo EPA-FFA 2g
Aspirin 300mg Placebo	Aspirin 300mg EPA-FFA 2g

Internet-based treatment assignment will be determined by a computer-generated pseudo-random code using random permuted blocks of randomly varying size, created by the Nottingham Clinical Trials Unit (CTU). Trial participants will be allocated with equal probability to each treatment arm with stratification by BCSP Centre.

SSP/RNs and Local Investigators will access the treatment allocation for each participant by means of a remote, internet-based randomisation system developed and maintained by the Nottingham CTU. The sequence of treatment allocations will be concealed until interventions have all been assigned and recruitment, data collection, and all other Trial-related assessments are complete. The actual allocation will not be divulged to either the staff at the BCSP site or the participant. The prescription produced by the randomisation system will reference specific trial treatment containers.

The Trial drug prescription will be signed by the local PI or a Co-I as defined by the site Delegation Log.

#### 4.2.4: Un-blinding

Participants, SSP/RNs, local Investigators and those assessing the outcomes will all be blinded to treatment assignment. The statistical analysis for the Trial will also be blind. The Data Monitoring Committee (DMC) may have access to un-blinded data but will have no contact with study participants.

Access to the sequence of treatment allocations will be confined to the Nottingham CTU Data Manager and a central pharmacy in case of out-of-hours un-blinding.

In the event of the need to break the code, usually due to emergency clinical need, the date and reason for breaking the code will be recorded on the web-based unblinding system. The local Hospital Pharmacy will have access to the web-based unblinding system in normal office hours (9am-5pm, Monday – Friday) and out of hours access will be via Leeds Pharmacy (0113 2433144 and ask for on-call pharmacist) who will keep a copy of all treatment allocations. Unblinding will only be performed if there is a medical emergency. For all other non-emergency requests, authorisation needs to be given by the CI.

However, for the majority of cases, unblinding will not be required because there is no antidote to the investigational treatments, and the medical care and usually the management of the participant would not be any different even if the treatment group assignment of the participant were known.

Any participant that is unblinded will take no further part in the Trial. Unblinding to participants or others involved in the conduct of the trial will be recorded in the protocol deviation log, and notified to the Trial Steering Committee (TSC), who will decide what action to take

#### **4.2.5: Participants who Withdraw**

Participants can withdraw at any time, without giving a reason and without compromising their future management. In the event of their withdrawal, data collected to date will not be erased and will be used in the final analyses where appropriate (this will be explained in the PIL).

Participants shall be withdrawn from the Trial if any of the following apply:

- Participant withdraws consent
- Participant lost to follow-up
- At any Trial Clinician's discretion
- New data with serious implications for participant safety become available regarding the IMPs
- Participant does not meet inclusion/exclusion criteria

In all cases the date and reason for withdrawal must be recorded on the CRF.

A maximum of three attempts should be made to contact any participant lost to follow up during the course of the study in order to complete assessments and retrieve any outstanding data and study medication / supplies.

#### **4.2.6: Managing / replacing participants who withdraw from the trial early**

Participants who withdraw from the Trial will still be part of the BCSP and their clinical care will be unaffected. Withdrawn participants will not be replaced.

No specific measures are advised if there is abrupt termination of the trial treatment because it is unlikely that this will affect participant safety.

#### **4.2.7: Definition for the End of Trial**

The end of trial is defined as "last participant's last visit".

### **5. TRIAL DRUG TREATMENT**

#### **5.1 General information on the products (trial drugs) to be used**

##### **Eicosapentaenoic acid in free fatty acid form (EPA-FFA)**

EPA-FFA is a naturally-occurring,  $\omega$ -3 PUFA which will be provided in gastro-resistant capsules of 500mg (see IB for additional information). EPA-FFA has not yet received marketing approval.

Several clinical studies indicate that EPA-FFA is well-tolerated at doses up to 2 g/day over periods up to 6 months (see Section 1.1). The principal undesirable effects are expressed through the gastrointestinal tract with diarrhoea, abdominal pain, nausea and vomiting. These are normally relatively mild in severity and can be minimised or removed by dosing with food or dose reduction to 1g daily.

##### **Aspirin**

Aspirin (acetylsalicylic acid) will be supplied as enteric-coated 300mg tablets (see aspirin SPC for additional information). These tablets have marketing approval in the EU.

##### **Placebo for EPA-FFA and Aspirin**

EPA-FFA placebo consist of gastro-resistant capsules of capric and capryllic acid triglycerides which has previously been used in Phase III clinical evaluation of EPA-FFA<sup>23</sup>.

The placebo for aspirin will consist of the same excipients as in the active formulation of the drug minus the active ingredient.

## **5.2 Frequency and duration of the trial drugs**

Two 500mg gastro-resistant capsules of EPA-FFA (or placebo) will be taken orally twice daily with food giving a total daily dose of 2g.

One 300mg enteric-coated aspirin tablet (or placebo) will be taken orally once a day with food.

The Trial treatment is taken daily from the date randomisation to the day before the surveillance colonoscopy, between 350-360 days.

The Trial treatment will not be available to the participants via the seAFood Polyp Prevention Trial team when they have finished the Trial.

## **5.3 Administration / handling of the trial drugs**

### **5.3.1 Packaging and labelling**

This will be in accordance with UK regulatory requirements. The containers will be clearly marked and have a unique identification number.

Bulk supplies of the EPA-FFA, aspirin and placebo capsules and tablets will be delivered to Stockport Pharmaceuticals at Stepping Hill Hospital in Stockport, for packaging into containers and labelling to allow preparation of randomized and blinded supplies.

### **5.3.2 Storage, dispensing and return**

Blinded supplies will require storage at Stockport Pharmaceuticals for distribution to participating UK centres under a web-based system control.

Trial treatments will be stored at room temperature below 25 °C. In the local pharmacy, all trial treatments should be stored in a secure location, in a temperature controlled environment, with a temperature log maintained daily, and may be dispensed only by specifically authorised personnel.

Each participating centre pharmacy be provided with a Pharmacy File and take receipt of numbered supplies from Stockport Pharmaceuticals.

At the baseline visit (v1), sites will log on to a web-based randomisation system and will enter the requested participant details.

These details will be transferred to a Trial specific prescription which will supply enough Trial medication for 6 months. The pharmacy will complete the dispensing process by addition of the participant's name, subject number, date of dispensing and visit number, to each allocated container. This process will be repeated again at visit 4 and supply will be dispensed for the next 6 months of Trial medication.

The local site Investigator is responsible for ensuring Trial treatment accountability, including reconciliation of trial treatment and maintenance of trial treatment records, throughout the course of the study in accordance with UK regulatory requirements. Responsibility may be delegated to site pharmacy clinical trials staff. Upon receipt of the trial treatment, delivery details will be checked for accuracy and receipt acknowledged by signing or initialling and dating the documentation provided. In addition, receipt will be acknowledged in the web-based system by the local Pharmacy team who have access to the stock control web-based system. Dispensing will be recorded on the appropriate accountability forms.

Unused Trial treatment must not be discarded or used for any other purpose than the present study. Trial treatment that has been dispensed to a participant must not be re-dispensed to a different participant. Unused trial treatment will be returned at the out-patient visit (at 27 weeks) and the post-colonoscopy visit (at 54 weeks) and returned to the local pharmacy.

Residual numbers of tablets capsules will be recorded to assess compliance and accountability completed before local destruction by the SSP or RN and recorded in the CRF.

### **5.3.3 Known Side Effects**

See Appendix C for a list of known side effects of gastro-resistant EPA-FFA and aspirin.

## **5.4 Concomitant Medications and Treatment**

Concomitant medications are all prescribed medications (drugs) being taken regularly by a participant on entry to the trial, and all medication prescribed on a regular basis in addition to the trial treatment during the trial.

However, in the seAFOod Polyp Prevention Trial, we will only be collecting information on certain classes of drug that may have an effect on colorectal adenoma development. This list is provided in the CRF and the CRF guidelines . These concomitant medications and treatments must be documented on the CRF (using generic name and/or trade name as appropriate) and also in the participant's medical records. Include any changes to these treatments and dosage.

Medications that are prohibited whilst in the trial are warfarin (any dose) or any other anti-coagulant therapy, or any other anti-platelet agent such as clopidogrel, regular (>3 x per week) prescribed or OTC aspirin, regular (>3 x per week) prescribed or OTC non-steroidal anti-inflammatory drug (NSAID), ongoing or planned use of fish oil supplements and Methotrexate use at a weekly dose of 15 mg or more. Please note that participant self-prescription (not on the recommendation of a Doctor) of aspirin or another NSAID or a fish oil supplement is not an exclusion if the participant is willing to stop use of aspirin or another NSAID or a fish oil supplement for at least the duration of the Trial.

Concomitant medications/treatment should be kept to a minimum during the trial. However, if considered necessary for the participant's welfare and unlikely to interfere with the trial drug, they may be given at the discretion of the investigator according to the local standard of care.

Participants should be advised to avoid taking any aspirin-containing over-the-counter analgesia and to take an alternative (such as paracetamol) when pain relief is necessary. Examples of medication that contains aspirin are Askit Powder Sachets, Beechams Powders, Disprin and Anadin. They should also be advised to avoid taking NSAID's such as Ibuprofen and also avoid fish oil supplements which can be labelled as 'Omega 3 preparations' or fish oil derivatives. Participants are advised to check with the pharmacist before purchase. Any use will be recorded in the concomitant medication log in the CRF.

## **5.5 Special warnings and precaution for use with other concomitant medications**

Although it is not expected<sup>33</sup>, increased bleeding risk associated with EPA-FFA alone, or in combination with aspirin, has not previously been evaluated in a large Phase III study. Therefore, we will recommend that all participants stop study drugs 10 days prior to, and for 4 days after, any surgical procedure taking place during the intervention period.

Concomitant aspirin therapy alone is not stopped routinely for BCSP colonoscopy. Therefore, trial medication will continue until the day of surveillance (exit) colonoscopy.

Glucocorticoids (with the exception of hydrocortisone as replacement therapy for Addison's disease) and other non-steroidal anti-inflammatory drugs may increase the risk of gastrointestinal ulcers and bleeding in combination with aspirin. Concomitant proton pump inhibitor therapy should be considered in order to reduce gastrointestinal bleeding risk.

Low dose aspirin reduces renal uric acid excretion and may precipitate gout in predisposed individuals.

Systematic review has not found any evidence of worsening of glycaemic control in diabetics taking omega-3 preparations<sup>37</sup>, although there is a report of short-term loss of glycaemic control in diabetic patients taking 4g EPA daily<sup>38</sup>. Trial participants with diabetes mellitus should be reminded to monitor their glycaemic control by their usual means during the Trial.

## **5.6 Contra-indicated medication**

Methotrexate at a weekly dosage of 15 mg or more, warfarin at any dose or any other anti-coagulant therapy, or any other anti-platelet agent such as clopidogrel, regular (>3 times per week) prescribed or OTC any dose aspirin or regular (>3 times per week) prescribed or OTC non-aspirin NSAID should not be used during the Trial. If any of these medications are required, the participant should be withdrawn from the Trial.

## **5.7 Dose Modifications**

If side-effects occur which the Investigator suspects to be related to EPA-FFA, the manner in which the capsules are taken should be reviewed using the flow chart in the CRF e.g. have the capsules been taken with food? If the side-effect persists, the dose of EPA-FFA or placebo will be temporarily reduced to 1g per day aiming to increase the dose back to 2g daily within one week. Dose modification should be recorded in the medical notes and the CRF. The aspirin dose cannot be modified.

## 5.8 Drug Supply

SLA Pharma AG will supply gastro-resistant capsules of 500mg EPA-FFA and identical placebo.

Bayer-Schering Pharma AG will supply enteric-coated tablets of 300mg aspirin and identical placebo.

## 5.9 Management of trial treatment overdose

### EPA-FFA

There are no recommendations for treating an EPA-FFA overdose.

### Aspirin

A distinction is made between chronic acetylsalicylic acid over-dosage (with predominantly central nervous manifestations such as drowsiness, dizziness, confusion or nausea) and acute intoxication.

The cardinal feature of acute intoxication is severe disruption of the acid-base balance. The apparent clinical picture is that of metabolic acidosis. However, the actual condition is a combination of respiratory and metabolic acidosis. This is compounded by impairment of electrolyte balance including major potassium loss. Symptoms of mild acute intoxication (200-400 µg/ml) are hypoglycaemia, skin rashes and gastrointestinal haemorrhaging, hyperventilation, tinnitus, nausea, vomiting, disturbed vision and hearing, headache, dizziness and confusion. With severe intoxication (above 400 µg/ml), delirium, tremor, difficult breathing, sweating, dehydration, hyperthermia and coma may occur.

The therapeutic measures for treatment of intoxication depend upon the extent, stage and clinical symptoms of the intoxication. They comprise the standard measures for decreasing absorption of the active ingredient, monitoring of the water and electrolyte balance, impaired temperature regulation and respiration. In severe cases, haemodialysis may be necessary.

## 5.10 Discontinuation of Treatment

If an adverse drug reaction (ADR; serious or non-serious) occurs, the Investigator or attending physician has the responsibility for and will take direct and appropriate action to provide care for the participant and to decide whether or not the Trial treatment should be discontinued.

However, it is recommended that unless clear contraindications arise, the Trial treatment be continued, or stopped only briefly. This is much preferred to permanently discontinuing the participant from the Trial treatment. Therefore, every attempt should be made to have the participant restart the Trial treatment if medically appropriate.

In all cases, the reasons for discontinuation of trial treatment must be recorded on the CRF and if the investigator has recorded more than one reason, they should indicate the main reason.

Participants may also be discontinued permanently from the trial treatment if the participant needs treatment with Methotrexate greater than or equal to 15 mg weekly, any dose of warfarin or any other anti-coagulant therapy, or any other anti-platelet agent such as clopidogrel or due to any other situation which the Investigator judges to be relevant.

## **6. TRIAL SCHEDULE**

### **6.1 Visit by visit schedule (see Appendices A & B)**

#### **Trial information provided, T= -2 weeks (Pre-trial BCP colonoscopy)**

Potential participants to the Trial are identified during their scheduled BCSP screening colonoscopy. Any individuals that are classified as 'high risk' according to the BCSP guidelines will be provided with written Trial information by a SSP/RN. The patient has until his or her routine out-patient follow-up visit to consider taking part in the Trial. The details of every identified 'high risk' BCSP patient (initials, date of birth and date given Trial information) will be added to the screening log.

#### **Consent and Randomisation, Visit 1 T= 0 weeks (upto 4 weeks post BCSP colonoscopy)**

Patients routinely attend the hospital for out-patient follow-up with a SSP/RN within two weeks of the BCSP screening colonoscopy. Eligible and willing participants will be asked to provide written informed consent, a full medical history will be taken and they will be randomised to a Trial treatment group (see Section 4.2.3 above). A signed Trial prescription will be issued for the supply of Trial treatment for 6 months, in the first instance. The local Hospital Pharmacy will dispense the Trial treatment. The participants are instructed to start taking their Trial medication on the day after the randomisation visit. A blood sample (2 x 6 ml K<sub>2</sub>EDTA Vacutainer tubes (purple cap)) and 5-10 ml urine specimen will be obtained during this visit to help elucidate the mechanisms of chemoprevention using various techniques (see Section 6.3 for more details).

In addition, participants will be requested to complete a pre-treatment, validated 'fish' Food Frequency Questionnaire (FFQ) so that any change in dietary  $\omega$ -3 PUFA intake during Trial involvement can be determined<sup>39</sup>.

#### **Telephone call Visit 2 T= 2 weeks (1-3 weeks post visit 1)**

Two weeks after starting the Trial treatment, the participants will be contacted by the SSP/RN by telephone to ask about any symptoms or new medical problems since the last contact and to remind the participant to take their Trial treatment as directed.

#### **Telephone call Visit 3 T= 12 weeks (11-12 weeks post visit 1)**

A second telephone contact will be conducted with the participant 12 weeks after starting the Trial treatment. The SSP/RN will again ask about any symptoms or new medical problems since the last contact and remind the participant to take their Trial treatment as directed.

#### **Out-patient Visit 4 T= 25 weeks (24-26 weeks post BCSP colonoscopy)**

At 6 months, participants will be invited to attend the BCSP Centre, at which time a mid-treatment blood and urine specimen will be collected as during the Consent and Randomisation visit. Participants will be asked about any symptoms or new medical problems since the last contact. Any unused Trial treatment will be collected and checked for compliance. The participant will receive a new prescription for Trial treatment for a further 6 months until surveillance colonoscopy.

#### **Telephone call Visit 5 T= 38 weeks (37-39 weeks post visit 1)**

A third telephone contact will be conducted with the participant at 38 weeks after starting the Trial treatment. The SSP/RN will again ask about any symptoms or new

medical problems since the last contact and remind the participant to take their Trial treatment as directed.

### **Exit colonoscopy Visit 6 T= 50 weeks (48-56 weeks post BCSP colonoscopy)**

Trial participants will be asked to take the last dose of Trial treatment on the day before their scheduled colonoscopy. A blood and urine specimen (post-treatment) will be obtained, as during the Consent and Randomisation visit, before the colonoscopy is done. At this colonoscopy, 4 random biopsies of macroscopically normal rectal mucosa (at least 2 cm from any polyp) will be collected for analysis in the Trial.

Adenoma outcomes (including data on 'advanced' adenoma criteria) at the one year surveillance colonoscopy will be collected as per usual BCSP practice including the number, site and size of all adenomas.

### **Routine post-colonoscopy Visit 7 T= 52 weeks (1-3 weeks post visit 6)**

All participants will be seen after surveillance colonoscopy as part of routine BCSP follow-up when a second 'fish' FFQ will be completed. At this out-patient visit, the timing of further colonoscopic surveillance in the BCSP will be confirmed and noted.

### **The opportunity for long-term follow-up in the BCSP**

Individuals with repeat 'high risk' findings at surveillance colonoscopy are recommended to undergo repeat annual surveillance in the BCSP as per BSG guidelines<sup>35</sup>. Individuals with less than 5 adenomas smaller than 10 mm in diameter are re-classified as 'intermediate risk' for three year surveillance colonoscopy. Even if there are negative or 'low risk' (1-2 small adenomas) findings at subsequent colonoscopies, original 'high risk' individuals are expected to have at least two further examinations over a period of six years before surveillance within the BCSP is stopped.

Therefore, the BCSP database can be used to monitor longer-term colonoscopic outcomes accurately following the intervention phase of the seAFOod Trial. This is important in order to determine whether there are prolonged benefits from short-term intervention and also rule out any possibility of 'rebound' polyp recurrence. Consent will be obtained from seAFOod Polyp Prevention Trial participants, prior to study entry, for the Trial team to access BCSP data on colonoscopic outcomes during BCSP surveillance up to six years after their involvement in the Trial (irrespective of other interventions individual participants may have received during BCSP follow-up). Any analysis of BCSP outcomes in seAFOod Polyp Prevention Trial participants will be directed by the primary and secondary Trial end-points, as well as future developments in the BCSP and CRC chemoprevention. Therefore, this analysis is not formally included in the Trial protocol.

## **6.2 Summary trial schedule**

See Appendix A

## **6.3 Laboratory mechanistic and biomarker studies**

### **6.3.1 Transport and Storage of the Samples**

Each Trial BCSP Centre will have a 4°C bench-top centrifuge and a -20°C freezer with electronic data monitoring and alarm in order to avoid *ex vivo* degradation of lipid mediators. A member of the site research team will use fresh blood to prepare plasma, leucocyte (buffy coat) and erythrocyte preparations (8 x 3 ml tubes) by a one-stage centrifugation step for immediate aliquoting and temporary storage -20°C. The urine will be

stored as 2 x 5 ml aliquots at -20°C. The four rectal biopsies will be frozen immediately as two biopsy pairs at -20°C.

The frozen samples will be transported, in an anonymised manner, on dry ice by a specialised Courier at tri-monthly intervals to the central -80°C storage facility in the Good Clinical Laboratory Practice (GCLP) Yorkshire Experimental Cancer Medicine Centre (ECMC) laboratory in the Institute of Cancer Therapeutics in Bradford.

After the Trial has finished, all biological samples will be stored in the Institute of Cancer Therapeutics in Bradford under a HTA licence.

Details of sample collection, sample storage and laboratory measurements will be described in the seAFood Polyp Prevention Manual that will be provided to each site.

### **6.3.2 Laboratory Analyses**

All analyses will be conducted at the Good Clinical Laboratory Practice (GCLP) Yorkshire Experimental Cancer Medicine Centre (ECMC) laboratory in the Institute of Cancer Therapeutics in Bradford (blood, urine and rectal mucosal samples) and the Leeds Institute of Molecular Medicine (polypectomy specimens). Brief details of the laboratory studies on blood, urine, and rectal mucosal samples, as well as on the polypectomy specimens, obtained during the Trial are included below. Full details of the laboratory analyses are available in Appendix D: The seAFood Polyp Prevention Trial protocol for laboratory studies.

#### *Measurement of PUFAs*

Erythrocytes and rectal mucosa will be used for simultaneous measurement of two  $\omega$ -3 PUFAs (EPA, DPA) and one  $\omega$ -6 PUFA (AA) by gas chromatography-mass spectrometry (GC-MS).

#### *Measurement of bioactive lipid mediators*

Liquid chromatography-tandem mass spectrometry (LC/MSx2) will be used to analyse the urine for PGE-M (11 $\alpha$ -hydroxy-9,15-dioxo-2,3,4,5-tetranor-prostane-1,20-dioic acid) levels and PGE<sub>3</sub> metabolites (PGE<sub>3</sub>-M1 and PGE<sub>3</sub>-M2). Plasma and rectal mucosa biopsies will be analysed using LC/MSx2 to detect multiple lipid mediators (15*R*-HETE, 15-epi-LXA4, 18*R*-HEPE, RvE1, PGE<sub>2</sub>, PGE<sub>3</sub>) as described in Appendix D.

#### *Immunohistochemistry for COX-2*

Formalin-fixed, paraffin-embedded polypectomy specimens from the screening (entry) and surveillance (exit) colonoscopies will be obtained from BCSP Centres for immunohistochemistry for COX-2.

#### *Genomic DNA extraction*

The leucocyte preparation will be used to extract genomic (g) DNA. Genotype studies will be carried out when clinical outcome and bioactive lipid mediator data are available and a hypothesis(es) can be generated regarding the role of particular genes in chemoprevention by EPA and/or aspirin.

## **7. PHARMACOVIGILANCE**

### **7.1 Defining Adverse Events**

An adverse event (AE) is any unfavourable and unintended sign, symptom, syndrome or illness that develops or worsens during the period of observation in the study. An AE does include a / an:

1. exacerbation of a pre-existing illness.

2. increase in frequency or intensity of a pre-existing episodic event or condition.
3. condition detected or diagnosed after medicinal product administration even though it may have been present prior to the start of the study.
4. continuous persistent disease or symptoms present at baseline that worsen following the start of the study.

The SSP/RN will enquire specifically about dyspepsia, nausea, abdominal pain, halitosis, diarrhoea, bleeding episodes (including haematemesis/melaena) and diagnosis of stroke at each follow-up visit and telephone call. Each participant will have a local contact phone number (usually the SSP/RN) in order to get advice about any problems occurring in the interim.

An AE does not include a / an:

1. medical or surgical procedure (e.g., surgery, endoscopy, tooth extraction, transfusion); but the condition that lead to the procedure is an AE.
2. pre-existing disease or conditions present or detected at the start of the study that did not worsen.
3. situations where an untoward medical occurrence has not occurred (e.g., hospitalisations for cosmetic elective surgery, social and / or convenience admissions).
4. disease or disorder being studied or sign or symptom associated with the disease or disorder unless more severe than expected for the participant's condition.
5. overdose of concurrent medication without any signs or symptoms.

## 7.2 Defining Serious Adverse Event

A Serious Adverse Event is defined in general as an untoward (unfavourable) event, which:

- is fatal. Death may occur as a result of the basic disease process. Nevertheless, all deaths occurring within 2 weeks of the last administration of the study agent must be treated as an SAE and reported as such. All deaths which may be considered as related to the trial agent, regardless of the interval, must be treated as a SAE and reported as such.
- is life-threatening
- requires or prolongs hospitalisation
- results in persistent or significant disability or incapacity
- is a congenital anomaly or a birth defect, or
- may jeopardise the participant and may require medical or surgical intervention to prevent one of the outcomes listed above
- Any other significant clinical event, not falling into any of the criteria above, but which in the opinion of the investigator requires reporting.

For the purpose of this Trial pre-planned elective hospital submissions will not be classed as a SAE.

### 7.3 Defining Suspected Unexpected Serious Adverse Reactions (SUSARs)

All SAEs assigned by the local Investigator as both *suspected* to be related to the trial drugs and *unexpected* are subject to expedited reporting. An event is unexpected when information is not consistent with the available product information or if it adds significant information on the specificity or severity of an expected reaction.

All investigators should refer to the Summary of Product Characteristics (SPC) and Investigators Brochure when determining whether a SAE is expected.

### 7.4 Reporting AEs

Information about AEs, whether volunteered by the participant, discovered by SSP/RN/Investigator questioning or detected through physical examination, laboratory test or other investigation will be collected and recorded on the CRF.

AEs will be collected for all participants from first dose of trial treatment until the final trial visit (which coincides with the BSCP routine post-colonoscopy visit) scheduled for 2 weeks after the last dose of trial treatment.

A summary of all captured AEs will be sent to the sponsor if requested.

### 7.5 Reporting SAEs

SAEs will be collected for all participants from first dose of trial treatment until the final trial visit (which coincides with the BSCP routine post-colonoscopy visit), scheduled for 2 weeks after the last dose of trial treatment.

SAE must be reported on a Sponsor-approved form and faxed through to the Trial Manager on 0115 9194430, within 24 hours of any member of the research team becoming aware of a potential SAE.

### 7.6 Reporting SUSARs

All SAEs assigned by the local Investigator (or another suitably qualified delegated Clinician) as both suspected to be related to trial treatment and unexpected will be discussed with the Chief Investigator (CI) or his deputy before reporting. If the consensus is that this is unexpected then such SAEs will be re-classified as SUSARs and will undergo expedited reporting to the REC and MHRA.

All SUSARs occurring whilst on Trial until the final trial visit (which coincides with the BSCP routine post-colonoscopy visit, scheduled for 2 weeks after the last dose of trial treatment) must be reported on a sponsor-approved form and faxed through to the Trial Manager on 0115 9194430, within 24 hours of any member of the research team becoming aware of the SUSAR.

The Nottingham CTU will inform the MHRA<sup>①</sup>, the Research Ethics Committee (REC)<sup>①</sup> and the Sponsor<sup>②</sup> of SUSARs within the following timescales.

- ① SUSARs resulting in Death or are deemed to be life-threatening must be reported to the REC and MHRA within **7 calendar days** of the CI (or their

designee) being aware of the event. Follow-up information must be reported within a further **8 calendar days**.

- ① Any SUSARs **not** resulting in Death or deemed to be life-threatening must be reported to the REC and MHRA within **15 Calendar days** of the CI (or their designee) being informed of the event. Follow-up information must be reported within a further **8 calendar days**.
- ② All SUSARs must be reported to the sponsor QA office (on 0113 392 6397) within 24 hours of the event being reported to the CI (or their designee).

SUSAR reporting to the MHRA website will be conducted by Nottingham CTU on behalf of the Sponsor.

## **7.7 Pregnancy**

Pregnancy is highly unlikely in female participants in this study as they will be post-menopausal. Male participants and their female partners of child bearing potential must use medically acceptable forms of contraception during the trial.

## **7.8 Development Safety Update Reports (DSUR)**

An DSUR must be submitted to the main REC, MHRA and the Sponsor on the anniversary of the Clinical Trial Authorisation being granted.

The DSUR will be compiled by Nottingham CTU and the CI must review and sign / date the report.

A copy of the DSUR will be send to SLA Pharma AG, Bayer-Schering Pharma AG and the Bowel Cancer Screening Programme Research Committee. (BCSPRC). The BCSPRC oversee research undertaken through the BCSP to ensure that BCSP participants are not harmed while taking part in the trial.

## **7.9 End of Trial Report**

Upon completing the Trial, as defined in 5.2.7 above, an end of Trial report must be submitted to the regulatory authorities within 90 days. A copy of this end of Trial report should also be submitted to the Sponsor's office.

The CI must sign and date the report.

# **8. DATA COLLECTION, SOURCE DATA AND CONFIDENTIALITY**

## **8.1 General**

All Trial staff and Investigators, staff at the Nottingham Clinical Trial Unit, the local BCSP sites and the Yorkshire Experimental Cancer Medicine Centre (ECMC) laboratory will endeavour to protect the rights of the Trial participants to privacy and informed consent, and will adhere to the Data Protection Act, 1998. Operationally this will include:

- consent from participants to record personal details including name, date of birth, address and telephone number, NHS ID, hospital ID, GP name and address
- appropriate storage, restricted access and disposal arrangements for participant personal and clinical details
- consent from participants for access to their medical records by appropriate

individuals from the Trial research staff, the sponsor or from regulatory authorities, where it is relevant to trial participation

- consent from participants for the data collected for the trial to be used to evaluate safety and develop new research.

The CRF will only collect the minimum required information for the purposes of the trial. If used, worksheets to help with completing the CRFs will be held securely at site, in a locked room, or locked cupboard or cabinet. Access to the trial documentation will be limited to the Trial staff and Investigators and relevant regulatory authorities. The Trial database will be held on a secure dedicated web server. Access will be restricted by user identifiers and passwords (encrypted using a one way encryption method). Laboratory specimens are only labelled with study ID. The ID key is only held at the site.

Information about the Trial in participant medical records / hospital notes will be treated in the same way as all other sensitive medical information.

Electronic data will be backed up every 24 hours to both local and remote media in encrypted format.

## 8.2 Archiving

In line with the principles of GCP / UK Clinical trial Regulations guidelines, at the end of the Trial, data will be securely archived at the sponsor site and each participating centre for a minimum of 15 years. Arrangements for confidential destruction will then be made. If a participant withdraws consent for their data to be used, it will be confidentially destroyed immediately. Study documentation / data must not be destroyed without the approval of the Sponsor.

## 9. STATISTICAL CONSIDERATIONS

### 9.1 Sample Size / Power Calculations

The sample size calculation is based on the RCT of the same dose and preparation of EPA-FFA in FAP patients by the CI<sup>23</sup>, the meta-analysis of aspirin RCTs by a co-I<sup>10</sup> and detailed audit data from the South of Tyne and Tees BCSP Centres collected by two of the co-Is. In order to detect a minimum 18% relative reduction in adenoma risk in each two-arm comparison (less than the 22% reduction in polyp number compared with placebo in the FAP Trial and below the absolute reduction in polyp number at one year [38%] in aspirin RCTs) from a 60% adenoma recurrence rate at surveillance colonoscopy to 49%, 678 evaluable 'high risk' individuals would need to be randomised equally to the four treatment arms, with 80% power at a 5% two-sided significance level.

The above standard practice for 2x2 factorial designs in the absence of interaction bases the sample size estimate on the two-arm comparison of treatment A vs placebo (and divides the total equally between the four arms). With the sample size of 678 based on this method there is, in fact, a slight reduction in power (to 75%) which arises if *both* treatments work, because then the overall comparison for treatment A is not 0.49 vs 0.6, but is 0.445 vs 0.545 (averaging over the placebo and treatment B arms).

To keep power at 80% for the above figures, a simulation using Stata v10 and employing the proposed analysis method indicates that we need 192 individuals per arm (total 768 evaluable 'high risk' individuals). If we assume a 15% drop-out rate, this increases to  $768/0.85 = 904$  individuals. If we allow for 40% ineligibility and unwillingness

to consent (we know that existing aspirin use is 20% in 'high risk' patients detected at screening colonoscopy in the South Tyneside and Tees BCSP Centres) then a total of  $904/0.6=1507$  'high risk' patients would need to be identified at BCSP screening colonoscopy.

For recruitment projections, we assume that we need to identify 1500 BCSP patients as 'high risk' at screening colonoscopy. We know from the National BCSP dataset that a realistic target for identification of 'high risk' patients in all BCSP Centres (which each serve a similar population size) is approximately 50 per year. Therefore, in practice, we expect to recruit from 15 BCSP Centres for approximately 2 years in order to identify  $15 \times 50 \times 2$  years 1 month = 1500-1562 'high risk' patients for Trial eligibility screening. We propose to use BCSP Centres restricted to the Northern and Eastern BCSP Regional Hubs in order to reduce Trial management costs and take advantage of existing Regional Hub networks of BCSP staff.

## 9.2 Statistical Analysis

### 9.2.1 Methods to be used

Analyses will be conducted by the Trial statistician based in the Nottingham CTU, using Stata v10 or above.

No adjustment for multiple significance testing has been made in the sample size estimate or in the analyses. We do acknowledge that there is disagreement about this topic among statisticians, but no claim for benefit will be made unless in the primary analysis the observed effect for a treatment is at least as great as a minimum clinically relevant difference (crd) of 11 percentage points (equivalent to an 18% relative reduction in adenoma recurrence – see Section 9.1) and is also statistically significant (as defined above). There is a negligible risk of making a false claim of benefit (this probability for two independent tests is estimated to be no more than 0.0051). The diagram below may help in understanding how the trial results will be interpreted:

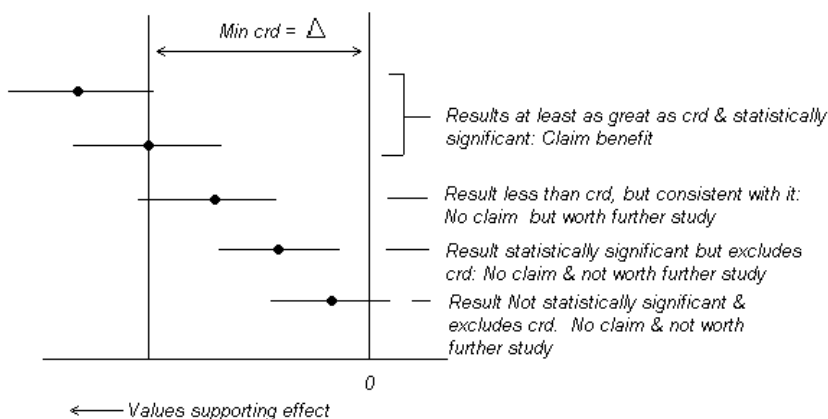

No formal interim analysis for efficacy is planned and hence there are no 'stopping rules'. The intention is not to stop the trial early unless there is very strong evidence of lack of safety. The main analysis team will not have access to these results, which will be communicated only in the form of a recommendation to the Trial Steering Committee by the DMC.

### 9.2.2 Assessment of efficacy

The primary analysis will follow the intention-to-treat principle using the Full analysis set following multiple imputation for missing data. The 2 x 2 factorial trial will be analysed by an ‘at the margins’ approach, which is justified by the lack of evidence of any interaction (see Section 1.1) between EPA and aspirin<sup>42</sup>. The effects of the interventions will use as an efficacy parameter the log relative risk estimated by a Poisson regression with robust standard errors to include treatment arm and relevant covariates as explanatory variables. Both interventions will be fitted simultaneously (with covariates). Centre will be handled as a random effect. Each treatment main effect will be declared as statistically significant if the corresponding 95% confidence limits for the efficacy parameter exclude zero. A formal test for interaction will be performed as a secondary analysis but it is recognised that this will lack power to detect anything but a very large effect.

As this is not a time-to-event analysis – the assessment for recurrence is only performed once at 52 weeks - and as all subjects will be followed for the same duration within a window of a few days the issue of censoring does not arise; however the response of subjects who withdraw or are otherwise lost to follow-up in that interval will be handled as missing data (see below).

The primary endpoint will also be assessed in a sensitivity analysis using the Per-protocol population.

#### Secondary endpoints

- Occurrence of “advanced” adenoma at 1 year. This will be handled in the same way as the primary endpoint.
- Number of adenomas per participant. This will employ a negative binomial model with robust standard error to allow for clustering by BCSP Centre
- Reclassification as “intermediate risk” will be handled in the same way as the primary endpoint.

The feasibility of studying a differential effect of chemoprevention on the location of adenoma recurrence will be explored, possibly using a Poisson random effects model with bivariate response (corresponding to polyp counts in the left and right colon) in which treatment and a baseline polyp count will be independent variables together with random intercepts corresponding to patient and BCSP Centre.

Bioactive lipid mediator data will be assessed using the Full analysis population (see Appendix D).

### 9.2.3 Assessment of Safety

This will be applied to the Safety population. All participants who receive at least one dose of treatment will be included in the safety analysis. Mis-randomised participants will be analysed as treated.

Treatment-emergent ADRs will be summarized by body system and preferred term. In addition, ADRs will be summarized by severity using the preferred term and the worst severity and causality recorded. The worst case will be assumed if severity or causality are missing.

SARs and ADRs that lead to study discontinuation will be summarized by treatment group and preferred term.

All participants who experience treatment-emergent ADRs will be listed, to include ID, treatment arm, system organ class, preferred term, unexpectedness, seriousness, severity, start and stop dates/times, action taken and outcome.

**Full details of all planned analyses will be specified in a separate Statistical Analysis Plan, to be finalised before data lock.**

#### **9.2.4 Analysis populations**

The following analysis populations will be used:

- Safety set: All randomised participants who receive at least one dose of a Trial drug. Mis-randomised participants will be analysed as treated
- Full Analysis set: All randomised participants, for whom the primary endpoint is available or can be imputed. It is analysis of this population which is in accordance with the “intention to treat” (ITT) principle.
- Per protocol set: All participants in the Full Analysis set who are deemed to have no major protocol violations that could interfere with the objectives of the study.

Protocol violations are defined as:

- More than 50% of trial medication returned in total
- Inadvertent use of OTC medication containing aspirin, NSAID’s or fish oil for more than 2 weeks in total
- Exit surveillance colonoscopy occurs either before 48 weeks or after 56 weeks after pre-trial screening BCSP colonoscopy.

#### **9.2.5 Missing data**

No missing values are expected for the key baseline covariates because these data must be submitted prior to randomisation.

Missing covariate and response values will be handled by multiple imputation using chained equations, by means of the Stata v10 add-in module *ice*. Plausible sets of explanatory variables for each variable with missing responses will be identified using the *pred\_eq* add-in module, using the whole data set, but omitting treatment arm. In particular the imputation for missing biomarker data will incorporate information on earlier response data and other variables thought likely to account for the missing data.

Once the sets of explanatory variables have been identified, separate data sets will be created for each treatment arm and 5 multiple imputations will be created for each arm, after ensuring that the primary response is included in each of the sets of explanatory variables. The multiply-imputed data sets will then be recombined for formal analysis, either using the *mim* command prefix, or if necessary a bespoke routine to estimate parameter values and combine them using Rubin’s rules.

A sensitivity analysis in which missing outcome data are assumed to be missing not at random will also be performed for the primary outcome and for response. This may be accomplished for example by replacing the imputed primary response values by the observed values least favourable to the active treatment and re-estimating the treatment effect.

## **10. DATA MONITORING**

### **10.1 Data Monitoring**

Details of monitoring of Trial data will be described in the monitoring plan and shall include confirmation of informed consent; source data verification; data storage and data transfer procedures; local quality control checks and procedures, back-up and disaster recovery of any local databases and validation of data manipulation. The Trial manager, or where required, a nominated designee of the Sponsor, shall carry out monitoring of Trial data as an ongoing activity. Monitoring visits to the site will allow sufficient time and access to facilities and source documents.

Entries on CRFs will be verified by inspection against the source data. A sample of CRFs will be checked on a regular basis for verification of all entries made. In addition the subsequent capture of the data on the Trial database will be checked. Where corrections are required these will carry a full audit trail and justification.

Trial data and evidence of monitoring and systems audits will be made available for inspection by the MHRA as required.

### **10.2 Quality Assurance**

The Sponsor has systems in place to ensure that there is reporting and appropriate action taken in respect of:

- (a) serious breaches of GCP, the trial protocol and the Clinical Trial Authorisation.
- (b) Urgent safety Measures
- (c) Protocol violations

A “serious breach” is a breach which is likely to effect to a significant degree –

- (a) the safety or physical or mental integrity of the participants of the trial; or
- (b) the scientific value of the trial.

Investigators will promptly notify the Sponsor QA Office of the following within the required timeframe, once they become aware of:

- (a) serious breaches of GCP, the trial protocol and the Clinical Trial Authorisation.
- (b) Urgent safety Measures
- (c) Protocol violations
- (d) Any amendments to the trial
- (e) Any changes the Clinical Trial Risk Assessment (form A).
- (f) any other issues as stated in the Research Sponsorship Agreement (RSA)

The Sponsor reserves the right to audit any site involved in the trial and authorisation for this is given via the RSA.

### **10.3 Trial Steering Committee**

The role of the TSC is to provide overall supervision for a trial on behalf of the Trial Sponsor and Trial Funder and to ensure that the trial is conducted to the rigorous standards set out in the Medical Research Council’s (MRC) Guidelines for Good Clinical Practice. It should be noted that the day to day management of the trial is the responsibility of the Investigators and the Chief Investigator

- In particular, the TSC should concentrate on progress of the trial, adherence to the protocol, participant safety and the consideration of new information of relevance to the research question.
- The safety and well-being of the trial participants are the most important considerations and should prevail over the interests of the science and society.
- The TSC should provide advice, through its chair, to the Chief Investigator(s), the Trial Sponsor, the Trial Funder, the Host Institution and the Contractor on all appropriate aspects of the trial.
- Membership of the TSC should be limited and include an independent Chair, at least two other independent members, one or two principal investigators and, where possible, a consumer representative. Involvement of independent members provides protection for both Trial Participants and the Principal Investigator(s).
- Representatives of the Trial Sponsor and the Trial Funder should be invited to all TSC meetings
- Responsibility for calling and organising TSC meetings lie with the Chief Investigator, in association with the Chair. The TSC should meet at least annually, although there may be periods when more frequent meetings are necessary.
- There may be occasions when the Trial Sponsor or the Trial Funder will wish to organise and administer these meetings for particular trials. In the EME Programme's case this is unlikely, but it reserves the right to convene a meeting of the TSC in exceptional circumstances.
- The TSC will be asked to comment in detail on extension requests or substantial changes to protocol.

## 10.4 Data Monitoring Committee

The main features of the DMC are as follows:

- It is the only body involved in a trial that has access to the unblinded comparative data.
- The role of its members is to monitor these data and make recommendations to the TSC on whether there are any ethical or safety reasons why the trial should not continue.
- The safety, rights and well-being of the trial participants are paramount.
- The DMC considers the need for any interim analysis advising the TSC regarding the release of data and/or information.
- The DMC may be asked by the TSC, Trial Sponsor or Trial Funder to consider data emerging from other related studies.
- If funding is required above the level originally requested, the DMC may be asked by the Chief Investigator, TSC, Trial Sponsor or Trial Funder to provide advice and, where appropriate, information on the data gathered to date in a way that will not compromise the trial.
- Membership of the DMC should be completely independent, small (3 – 4 members) and comprise experts in the field, eg, a clinician with experience in the relevant area and an expert trial statistician.
- Responsibility for calling and organising DMC meetings lies with the Chief Investigator, in association with the Chair of the DMC. The project team should provide the DMC with a comprehensive report, the content of which should be agreed in advance by the Chair of the DMC.
- The DMC should meet at least annually, or more often as appropriate, and meetings should be timed so that reports can be fed into the TSC.

Independence, in respect of the DMC, is defined as independent from the Chief Investigator, TSC and Host Institution.

## **11. ETHICAL CONSIDERATIONS**

The trial will be performed in accordance with the recommendations guiding ethical research involving human participants adopted by the 18th World Medical Assembly, Helsinki, Finland, 1964, amended at the 48<sup>th</sup> General Assembly, Somerset West Republic of South Africa, October 1996. Informed written consent will be obtained from the participants prior to randomisation/registration into the study. The right of a patient to refuse participation without giving reasons must be respected. The participant must remain free to withdraw at any time from the study without giving reasons and without prejudicing his/her further treatment. The study will be submitted to and approved by a main Research Ethics Committee (REC) and the appropriate Research & Development (R&D) department for each participating centre prior to entering participants into the study.

## **12. STATEMENT OF INDEMNITY**

The University of Leeds is able to provide insurance to cover for liabilities and prospective liabilities arising from negligent harm. They may, in certain circumstances provide insurance cover for claims arising from non-negligent harm. Clinical negligence indemnification will rest with the participating NHS Trust or Trusts under standard NHS arrangements.

## **13. PUBLICATION POLICY**

The results of this trial will be presented at national and international meetings. They will also be submitted for publication in peer-reviewed journals. The investigators will follow International Committee of Medical Journal Editors (ICMJE) guidelines.

Participants who wish to receive information about the results from the Trial can ask their SSP/RN. They will be made aware that this will be some time after their participation in the Trial has finished.

## 14. TRIAL ORGANISATIONAL STRUCTURE

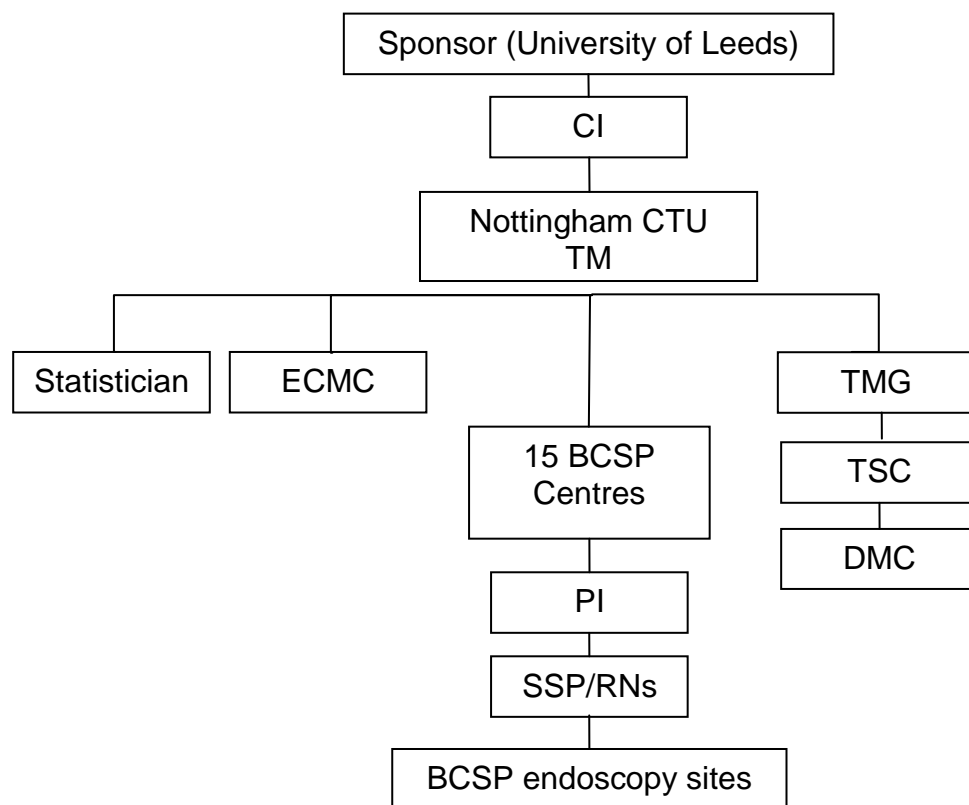

CI	Chief Investigator
CTU	Clinical Trials Unit
TM	Trial Manager
TMG	Trial Management Group
ECMC	Yorkshire Experimental Cancer Medicine Centre Laboratory in Bradford
TSC	Trial Steering Committee
DMC	Data Monitoring Committee
BSCP	NHS Bowel Cancer Screening Programme
PI	local Principal Investigator
SSP	Specialist Screening Practitioner
RN	Research Nurse

## 15. REFERENCES

1. Boursi B, Arber N. Current and future clinical strategies in colon cancer prevention and the emerging role of chemoprevention. *Curr Pharm Des* 2007;**13**:2274-82.
2. Hoff G, Grotmol T, Skovlund E et al. Risk of colorectal cancer seven years after flexible sigmoidoscopy screening: randomised controlled trial. *Br Med J* 2009;**338**:b1846.
3. Baxter N, Goldwasser M, Paszat L et al. Association of colonoscopy and death from colorectal cancer. *Ann Intern Med* 2009;**150**:1-8.
4. Atkin W, Edwards R, Kralj-Hans I et al. Once-only flexible sigmoidoscopy screening in prevention of colorectal cancer: A multicentre randomised controlled trial. *Lancet* 2010;**375**:1624-33.
5. Mandel J, Church T, Bond J et al. The effect of fecal occult-blood screening on the incidence of colorectal cancer. *N Engl J Med* 2000;**343**:1603-7.
6. Robertson D, Greenberg E, Beach M et al. Colorectal cancer in patients under close colonoscopic surveillance. *Gastroenterology* 2005;**129**:34-41.
7. Arber N, Levin B. Chemoprevention of colorectal neoplasia: The potential for personalized medicine. *Gastroenterology* 2008;**134**:1224-37.
8. Cuzick J, Otto F, Baron J et al. Aspirin and non-steroidal anti-inflammatory drugs for cancer prevention: an international consensus statement. *Lancet Oncol* 2009;**10**:501-7.
9. Flossman E, Rothwell P. Effect of aspirin on long-term risk of colorectal cancer: consistent evidence from randomised and observational studies. *Lancet* 2007;**369**:1603-13.
10. Cole B, Logan R, Halabi S et al. Aspirin for the chemoprevention of colorectal adenomas: meta-analysis of the randomized trials. *JNCI* 2009;**101**:256-66.
11. Hull M. Cyclooxygenase-2: How good is it as a target for cancer chemoprevention? *Eur J Cancer* 2005;**41**:1854-63.
12. Steinbach G, Lynch P, Phillips R et al. The effect of celecoxib, a cyclooxygenase-2 inhibitor, in familial adenomatous polyposis. *N Engl J Med* 2000;**342**:1946-52.
13. Funk C, Fitzgerald G. COX-2 inhibitors and cardiovascular risk. *J Cardiovasc Pharmacol* 2007;**50**:470-9.
14. Gerner E, Meyskens F. Combination chemoprevention for colon cancer targeting polyamine synthesis and inflammation. *Clin Cancer Res* 2009;**15**:758-61.
15. Lavie C, Milani R, Mehra M et al. Omega-3 polyunsaturated fatty acids and cardiovascular diseases. *J Am Coll Cardiol* 2009;**54**:585-94.
16. Smith W. Cyclooxygenases, peroxide tone and the allure of fish oil. *Curr Opin Cell Biol* 2005;**17**:174-82.
17. Calviello G et al. n-3 polyunsaturated fatty acids and the prevention of colorectal cancer. *Curr Med Chem* 2007;**14**:3059-69.
18. MacLean C et al. Effects of omega-3 fatty acids on cancer risk: A Systematic Review. *JAMA* 2006;**295**:403-15.
19. Lawson L, Hughes B. Human absorption of fish oil fatty acids as triacylglycerols, free acids, or ethyl esters. *Biochem Biophys Res Comm* 1988;**152**:328-35.
20. Fini L, Piazzini G, Ceccarelli C et al. Highly purified eicosapentaenoic acid acts as a potent COX-2 inhibitor and represses polyp formation in APC MIN/+ mice [abstract]. *Gastroenterology* 2009;**136**(Suppl 1):A761-2.
21. Courtney E et al. Eicosapentaenoic acid (EPA) reduces crypt cell proliferation and increases apoptosis in normal colonic mucosa in subjects with a history of colorectal adenomas. *Int J Colorectal Dis* 2007;**22**:765-76.
22. West N, Belluzzi A, Lund E et al. Eicosapentaenoic acid (EPA), as the free fatty acid, reduces colonic crypt cell proliferation in patients with sporadic colorectal polyps [abstract]. *Gut* 2009;**58**(Suppl II):A68.
23. West N, Clark S, Phillips R et al. Eicosapentaenoic acid reduces rectal polyp number and size in familial adenomatous polyposis. *Gut* 2010;**59**:918-25.
24. Hawcroft G, Loadman P, Belluzzi A et al. The effect of the omega-3 polyunsaturated fatty acid eicosapentaenoic acid on E-type prostaglandin synthesis and EP4 receptor signalling in human colorectal cancer cells. *Neoplasia* 2010 (in press).

25. Jin Y, Arita M, Zhang Q et al. Anti-angiogenesis effect of the novel anti-inflammatory and pro-resolving lipid mediators. *Invest Ophthalmol Vis Sci* 2009;**50**:4743-52.
26. Serhan C, Yacoubian S, Yang R. Anti-inflammatory and proresolving lipid mediators. *Annu Rev Pathol Mech Dis* 2008;**3**:279-312.
27. Arita M, Bianchini F, Aliberti J et al. Stereochemical assignment, anti-inflammatory properties, and receptor for the omega-3 lipid mediator resolvin E1. *J Exp Med* 2005;**201**:713-22.
28. Thorngren M, Gustafson A. Effects of 11-week increase in dietary eicosapentaenoic acid on bleeding time, lipids and platelet aggregation. *Lancet* 1981;**318**:1190-3.
29. Larson M, Ashmore J, Harris K et al. Effects of omega-3 acid ethyl esters and aspirin, alone and in combination, on platelet function in healthy subjects. *Thromb Haemost* 2008;**100**:634-41.
30. Katan M, Deslypere J, van Birgelen A et al. Kinetics of the incorporation of dietary fatty acids into serum cholesteryl esters, erythrocyte membranes, and adipose tissue: an 18 month controlled study. *J Lipid Res* 1997;**38**:2012-22.
31. Masoodi M, Mir A, Petasis N et al. Simultaneous lipidomic analysis of three families of bioactive lipid mediators leukotrienes, resolvins, protectins and related hydroxyl-fatty acids by liquid chromatography/electrospray ionisation tandem mass spectrometry. *Rapid Commun Mass Spectrom* 2008;**22**:75-83.
32. Benamouzig R, Uzzan B, Martin A et al. Cyclooxygenase-2 expression and recurrence of colorectal adenomas: Effect of aspirin chemoprevention. *Gut* 2010;**59**:622-9.
33. Harris W. Omega-3 fatty acids and bleeding – cause for concern? *Am J Cardiol* 2007;**99**(suppl):44C-6C.
34. Chan A, Jim M, Lam K et al. Prevalence of colorectal neoplasm among patients with newly diagnosed coronary artery disease. *JAMA* 2007;**298**:1412-9.
35. Cairns SR, Scholefield JH, Steele RJC et al. Guidelines for colorectal cancer screening and surveillance in moderate and high risk groups (update from 2002). *Gut* 2010;**59**:666-90.
36. Bensen S, Mott L, Dain B et al. The colonoscopic miss rate and true one-year recurrence of colorectal neoplastic polyps. *Am J Gastroenterol* 1999;**94**:194-9.
37. Farmer A, Montori V, Dinneen D et al. Fish oil in people with type 2 diabetes mellitus (Cochrane Review). The Cochrane Library, Issue 2, 2002. Oxford: Update Software.
38. Woodman R, Mori T, Burke V et al. Effects of purified eicosapentaenoic and docosahexaenoic acids on glycemic control, blood pressure, and serum lipids in type 2 diabetic patients with treated hypertension. *Am J Clin Nutr* 2002;**76**:1007-15.
39. Brouwer I, Zock P, Wever E et al. Rationale and design of a randomised controlled trial on supplemental intake of n-3 fatty acids and incidence of cardiac arrhythmia: SOFA. *Eur J Clin Nutr* 2003;**57**:1323-30.
40. Murphey L, Williams M, Sanchez S et al. Quantification of the major urinary metabolite of PGE<sub>2</sub> by a liquid chromatographic/mass spectrometric assay: Determination of cyclooxygenase-specific PGE<sub>2</sub> synthesis in healthy humans and those with lung cancer. *Anal Biochem* 2004;**334**:266-75.
41. Masoodi M, Nicolaou A. Lipidomic analysis of 27 prostanoids and isoprostanes by liquid chromatography/electrospray tandem mass spectrometry. *Rapid Commun Mass Spectrom* 2006;**20**:3023-9.
42. McAlister F, Straus S, Sackett D et al. Analysis and reporting of factorial trials. *JAMA* 2003;**289**:2545-53.

## 16. APPENDICES

### Appendix A: Visit table

(see also Appendix B)

	Pre-trial BCSP Colonoscopy  T=-2 weeks	Post-screening colonoscopy out-patient visit  <u>Visit 1</u> T=0 weeks (up to 4 weeks post BCSP colonoscopy)	Telephone call  <u>Visit 2</u> T= 2 weeks (1-3 weeks post visit 1)	Telephone call  <u>Visit 3</u> T= 12 weeks (11-13 weeks post visit 1)	Out-patient visit  <u>Visit 4</u> T= 25 weeks (24-26 weeks post BCSP colonoscopy)	Telephone call  <u>Visit 5</u> T= 38 weeks (37-39 weeks post visit 1)	Exit surveillance colonoscopy  <u>Visit 6</u> T=50 weeks (48-56 weeks post BCSP colonoscopy)	Routine visit post- surveillance colonoscopy <u>Visit 7</u> T=52 weeks (1-3 weeks post visit 6)
Provide Trial information (PIL)	X							
Check eligibility		X						
Informed consent		X						
Medical history/ demographic data		X						
Medication log		X	X	X	X	X	X	
Colonoscopy	X						X	
Colonoscopy results		X						X
Randomisation		X						
Trial drug dispensing		X			X			
Blood sample		X			X		X	
Urine sample		X			X		X	
FFQ		X						X
AE recording			X	X	X	X	X	X
Compliance			X	X	X	X	X	
Rectal biopsies							X	

## Appendix B: Trial Schema

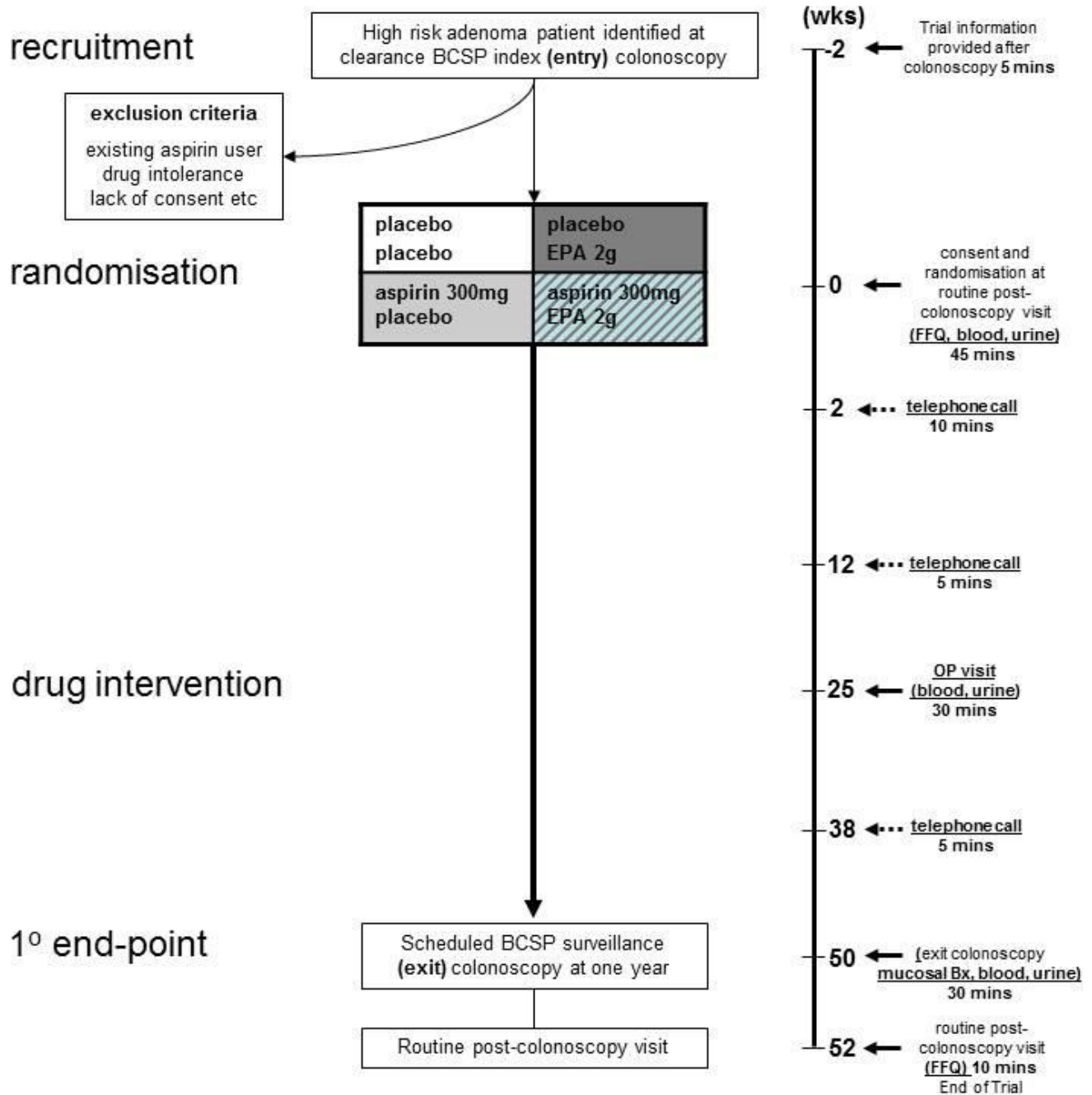

Trial interventions that are not part of routine BCSP care are labelled **bold and underlined**. Total direct research time for SSP/RNs per participant is estimated at 2 hours 20 minutes (**bold**).

## **Appendix C: Known side effects of the Trial drugs**

The list below will be used in this trial to determine the “expectedness” of reported ADRs, for all participating Centres. This list will be used to determine if an SAR which is considered “related” to trial medication will be classified as ICH Category I (serious, related, unexpected) or ICH Category II (serious, related, expected), for purposes of expedited reporting and regulatory compliance.

### **For EPA-FFA:**

Minor ADRs are:

- Loose stools or diarrhoea
- Abdominal cramps
- Bloating/distension
- Dyspepsia
- Nausea
- Fishy aftertaste
- Belching
- Halitosis

Other ADRs reported rarely or infrequently from previous RCTs of  $\omega$ -3 PUFAs include:

### **Blood and lymphatic disorders:**

Possible increased bleeding tendency

### **Endocrine disorders:**

Hypothyroidism.

### **Gastrointestinal disorders:**

Constipation, discoloured faeces, haematemesis/melaena, irritable bowel syndrome, mouth ulceration, proctalgia, overt rectal bleeding.

### **General disorders:**

Fatigue, influenza-like illness, malaise, peripheral oedema.

### **Immune system disorders:**

Seasonal allergy.

### **Infections and infestations:**

Ear infection, nasopharyngitis, tonsillitis, tracheitis, varicella infection, urinary tract infection.

### **Musculoskeletal and connective tissue disorders:**

Arthralgia, back pain, musculoskeletal pain.

### **Nervous system disorders:**

Dizziness, dysgeusia (abnormal taste sensation), headache, migraine.

### **Reproductive system and breast disorders:**

Prostatitis (penile and/or perianal pain)

**Renal and urinary disorders:**

Increased urinary frequency (Pollakiuria)

**Respiratory, thoracic and mediastinal disorders:**

Cough, pharyngo-laryngeal discomfort or pain.

**Skin and subcutaneous tissue:**

Erythema.

**For aspirin**

The following incidence rating is used to evaluate the frequency of side effects:

<b>Very common:</b> $\geq 1/10$
<b>Common:</b> $\geq 1/100$ to $< 1/10$
<b>Uncommon:</b> $\geq 1/1,000$ to $< 1/100$
<b>Rare:</b> $\geq 1/10,000$ to $< 1/1,000$
<b>Very rare:</b> $< 10,000$
<b>Not known:</b> frequency cannot be estimated from the available data

**Blood and lymphatic system disorders:**

*Rare to very rare:*

- Serious bleeding, such as cerebral bleeding, especially in participants with uncontrolled hypertension and/or concomitant treatment with anticoagulants, which in isolated cases may be potentially life-threatening.
- Bleeding, e.g. nosebleeds, bleeding gums, cutaneous bleeding or urogenital bleeding, possibly with prolongation of the bleeding time. This effect can persist for 4 to 8 days after use.

**Gastrointestinal disorders:**

*Common:*

- Gastrointestinal disorders such as heartburn, nausea, vomiting, abdominal pain and diarrhoea.

*Uncommon:*

- Gastrointestinal ulceration which in very rare cases can lead to perforation.
- Overt upper gastrointestinal bleeding (haematemesis and/or melaena).
- Iron deficiency anaemia due to occult blood loss from the gastrointestinal tract.

**Nervous system disorders:**

*Rare to very rare:*

- Cerebrovascular accident (stroke)

*Very rare:*

- Headache, dizziness, impaired hearing, tinnitus or mental confusion can be signs of an overdose.

**Skin and subcutaneous tissue disorders:**

*Uncommon:*

- Skin reactions (very rare cases ranging up to erythema multiforme).

**Immune system disorders:**

*Rare:*

- Hypersensitivity reactions of the skin, the respiratory tract, the gastrointestinal tract and the cardiovascular system), particularly in asthmatics. Symptoms could be hypotension, dyspnoea, rhinitis, stuffy nose, anaphylactic shock and angioneurotic oedema.

**Hepatobiliary disorders:**

*Very rare:*

- abnormal liver function tests.

**Renal and urinary disorders:**

*Uncommon:*

- Renal impairment.

**Metabolism:**

- Hypoglycaemia can occur in overdose.
- At low doses aspirin reduces the excretion of uric acid. This may precipitate an acute gout attack in predisposed participants.

## Appendix D: The seAFood Polyp Prevention Trial protocol for laboratory studies

### Background

#### *Mechanisms of the anti-neoplastic activity of EPA and aspirin*

The precise mechanism(s) by which EPA and aspirin have anti-CRC activity are not fully understood<sup>1-2</sup>. However, it is currently accepted that, even though these agents are likely to act via both COX-dependent and –independent mechanisms, modulation of COX activity plays an important role in their anti-neoplastic effects. EPA and aspirin are both potent inhibitors of cyclooxygenase (COX)-1 but they alter COX-2 activity in different ways (Figure 1)<sup>3</sup>.

Catabolism of AA by COX-2 leads to synthesis of 2-series prostaglandins (PGs) such as PGE<sub>2</sub>, which has known pro-tumorigenic activity<sup>4</sup>. EPA can substitute for AA at the *sn*-2 position in the phospholipid bilayer and is an alternative (although inefficient) substrate for COX-2, leading to production of equivalent 3-series PGs such as PGE<sub>3</sub>, which may have anti-tumorigenic properties<sup>3</sup>. EPA-FFA has recently been demonstrated to induce a 'PGE<sub>2</sub> to PGE<sub>3</sub> switch' in human CRC cells<sup>5</sup>.

Aspirin irreversibly acetylates COX-2, which drives production of so-called aspirin-triggered lipoxins (ATLs), such as 15-epi-lipoxin A<sub>4</sub>, by a 5-lipoxygenase (LOX)-dependent mechanism, via the intermediate 15*R*-HETE<sup>6</sup>. When EPA acts as a substrate for aspirin-acetylated COX-2, it leads to synthesis of an alternative eicosanoid 18*R*-hydroxyeicosapentaenoic acid (18*R*-HEPE), which has low level anti-inflammatory activity *per se* but no known anti-neoplastic properties. Conversion of 18*R*-HEPE to resolvin (Rv) E1 and E2 (which do have potent anti-inflammatory activity properties) occurs in a 5-LOX-dependent manner in experimental models<sup>7</sup>. RvE1 has been detected in the plasma of healthy volunteers treated with aspirin and EPA<sup>7</sup>, although RvE1 has not, to date, been measured in patients with colorectal neoplasia.

#### *Predictive biomarkers of anti-neoplastic activity of EPA and aspirin*

Membrane and plasma EPA levels are established biomarkers of dietary  $\omega$ -3 PUFA exposure in cancer epidemiological studies<sup>8</sup>. More recently, rectal mucosal EPA content was measured in the RCT of EPA-FFA in FAP patients<sup>9</sup>. Incorporation of EPA into rectal mucosa after oral EPA administration confirmed compliance and the bioavailability of EPA in the target tissue. However, there was no relationship between the individual percentage EPA mucosal content and the reduction in rectal polyp number (unpublished data). Therefore, there is a need for novel biomarkers based on the mechanism of action of EPA, which may predict individual therapeutic response.

The lipid products of COX-dependent metabolism after EPA and/or aspirin treatment noted above can be measured by liquid chromatography-tandem mass spectrometry (LC-MSx2)<sup>10-11</sup>. For example, measurement of urinary levels of the stable product of PGE<sub>2</sub> catabolism, termed PGE-M, is established in the Institute of Cancer Therapeutics, University of Bradford. Moreover, we have can detect 18*R*-HEPE is detectable in ng/ml quantities in plasma after aspirin (300 mg) and EPA-FFA (1 g) ingestion (unpublished data).

Recently, the pattern of COX-2 expression in the index adenoma has been demonstrated to predict the preventative efficacy of aspirin in the APACC polyp prevention trial<sup>12</sup>. This preliminary finding suggests that putative polypectomy predictive biomarkers such

as COX-2 and ChemR23 (the cell-surface RvE1 receptor<sup>7</sup>) should be evaluated in a large prospective RCT.

### **Aims of the mechanistic and biomarker studies**

The aims of the laboratory studies linked to the seAFOod Polyp Prevention Trial are:

1. to gain understanding of the mechanism(s) of the chemopreventative activity of EPA-FFA and aspirin, alone and in combination.
2. to identify a bioactive lipid mediator(s) as a predictive biomarker of chemopreventative efficacy of EPA-FFA and/or aspirin in participants with previous colorectal adenoma(s) before and/or during treatment.
3. to identify a predictive biomarker(s) of chemopreventative efficacy of EPA and aspirin in index colorectal adenoma tissue obtained at screening colonoscopy.
4. To understand how differences in participant genotype predict the chemopreventative efficacy of EPA and aspirin, alone and in combination

#### *The mechanism(s) of the chemopreventative activity of EPA and aspirin*

##### The 'PGE<sub>2</sub> to PGE<sub>3</sub> switch'

We and others have recently demonstrated that EPA therapy is associated with a reduction in tissue PGE<sub>2</sub> levels and the appearance of PGE<sub>3</sub> in colorectal mucosa<sup>13</sup> and CRC tissue (unpublished data) in rodents. We wish to determine, for the first time, that EPA treatment alone reduces PGE<sub>2</sub> synthesis and induces PGE<sub>3</sub> production in humans with a history of colorectal adenoma. We will measure stable urinary metabolites of PGE<sub>2</sub> and PGE<sub>3</sub> as a measure of systemic E-type PG synthesis, as well as PGE<sub>2</sub> and PGE<sub>3</sub> levels in rectal mucosa.

##### 18R-HEPE and RvE1 synthesis

Although 18R-HEPE and RvE1 have been detected in plasma of healthy volunteers who have taken aspirin and EPA<sup>7</sup>, it is not known whether patients with past or present colorectal neoplasia taking EPA generate detectable 18R-HEPE via either aspirin-acetylated COX-2 (in concurrent aspirin users) or by a cytochrome P450 monooxygenase-dependent pathway (in the absence of concurrent aspirin use). Moreover, it is not known whether appreciable amounts of RvE1 are produced in colorectal adenoma patients in the absence of overt inflammation. Therefore, we aim to measure 18R-HEPE and RvE1 (and RvE2 if RvE1 is detected) levels in plasma (and rectal mucosa, if detectable in plasma).

#### *Predictive lipid biomarkers of chemopreventative efficacy of EPA and aspirin*

The seAFOod Polyp Prevention Trial is an excellent opportunity to determine whether levels of PUFAs and/or downstream lipid mediators, or their stable urinary metabolites, in blood and urine predict adenoma outcome in a large number of participants, who are either untreated (placebo) or have taken a putative chemoprevention agent targeting lipid signalling pathways. The following PUFAs and downstream lipid mediators may be measured (see Methods below):

- Plasma
  - 18R-HEPE
  - RvE1 (RvE2)
  - 15R-HETE
  - 15-epi-lipoxin A<sub>4</sub>
- Urine
  - PGE-M
  - PGE<sub>3</sub>-M1 and/or PGE<sub>3</sub>-M2

The final list of predictive biomarker candidates that will be assessed will be dependent on which lipid mediators are detected in the preliminary, mechanistic studies.

#### *Predictive (adenoma) tissue biomarkers of chemopreventative efficacy of EPA and aspirin*

In the first instance, we will perform immunohistochemistry for COX-2 in the large series of archival polypectomy specimens available through the seAFOod Trial in order to substantiate the preliminary data recently published by Benamouzig and colleagues<sup>12</sup>. Other tissue analyses eg. immunohistochemistry for the RvE1 receptor ChemR23 will be driven by the other clinical and laboratory data that emerges from the Trial. For example, evidence that plasma 18R-HEPE and/or RvE1 levels predict adenoma recurrence in EPA users will prompt ChemR23 studies in this group.

#### *Does genotype predict the chemopreventative efficacy of EPA and aspirin, alone and in combination?*

Several genotypic variants are associated with colorectal adenoma risk<sup>14-15</sup> and efficacy of aspirin chemoprevention<sup>15-16</sup>. For example, the *ornithine decarboxylase* G316A variant was associated with reduced risk of adenoma recurrence and a greater risk reduction in aspirin users in the ukCAP Trial<sup>16</sup>. Moreover, the minor G allele of the single nucleotide polymorphism (SNP) rs4648310 (+8897A/G) in the 3' UTR of the *COX-2* gene was associated with lower adenoma recurrence risk in Aspirin/Folate Polyp Prevention Study patients with a non-significant suggestion that the G allele predicted aspirin chemopreventative efficacy, at least for the 81 mg dose<sup>17</sup>. SNPs in *UDP glucuronyltransferase 1A6* and *cytochrome P450C9* alter aspirin metabolism and may affect colorectal adenoma risk in aspirin users<sup>14-15</sup>. The *COX-2* SNP +8897A/G has also been demonstrated to abrogate the positive association between prostate cancer and dietary  $\omega$ -3 PUFA intake<sup>18</sup>. A recent genome-wide association study has identified several *desaturase* and *elongase* genes involved in fatty acid metabolism that predict plasma  $\omega$ -3 and  $\omega$ -6 PUFA levels suggesting that genotype may modulate tissue EPA levels<sup>19</sup>. Therefore, polymorphisms in genes controlling EPA and aspirin bioavailability and mechanism of action could affect chemopreventative efficacy of these agents and potentially find clinical use as predictive biomarkers in future 'personalised' chemoprevention strategies. Adenoma outcome and lipid biomarker data from the seAFOod Polyp Prevention Trial will be used to generate a testable hypothesis(es) that genetic polymorphisms are predictive of chemopreventative efficacy.

## **Methods**

### *Biological sample handling and storage*

Each Trial BCSP Centre will have a 4°C bench-top centrifuge and a -20°C freezer with electronic data monitoring and alarm in order to avoid *ex vivo* degradation of lipid mediators.

A SSP/RN will produce plasma, leucocyte and erythrocyte preparations from fresh whole blood by a one-stage centrifugation step for immediate aliquoting and temporary storage -20°C. Urine will also be stored as 2 x 5 ml aliquots at -20°C. Four rectal biopsies will be frozen immediately as two biopsy pairs at -20°C. Frozen samples will be transferred on dry ice by specialised Courier (Biocair) bi-monthly to a central -80°C storage facility in the Good Clinical Laboratory Practice (GCLP) Yorkshire Experimental Cancer Medicine Centre (ECMC) laboratory in the Institute of Cancer Therapeutics in Bradford.

Standard Operating Procedures for biological sample handling and storage by SSP/RNs in the BCSP Centres and by University of Bradford staff in the Institute of Cancer Therapeutics in Bradford will be provided.

### *Measurement of membrane PUFA content*

Two  $\omega$ -3 PUFAs (EPA, DPA) and one  $\omega$ -6 PUFA (AA) will be measured simultaneously in erythrocyte membranes and rectal mucosa (2 biopsies) by gas chromatography-mass spectrometry (GC-MS) as described<sup>9</sup>.

### *Measurement of lipid mediators by liquid chromatography-tandem mass spectrometry*

#### Urinary PGE-M

11 $\alpha$ -hydroxy-9,15-dioxo-2,3,4,5-tetranor-prostanoic acid (commonly termed PGE-M) is a stable metabolite of PGE<sub>2</sub>, which can be detected in human urine<sup>20</sup>. Urinary PGE-M levels are believed to reflect systemic PGE<sub>2</sub> synthesis rather than renal tubular cell PGE<sub>2</sub> production<sup>20</sup>. Urinary PGE-M levels (ng/ $\mu$ g creatinine) are measured to GCLP standards by LC/MSx2 in the ECMC laboratory in Bradford.

#### Urinary PGE<sub>3</sub> metabolites

There is currently no established urinary biomarker of PGE<sub>3</sub> synthesis. It has been reported that a gas chromatography (GC)/MS technique was unable to detect a urinary PGE<sub>3</sub> metabolite (7 $\alpha$ -hydroxy-5,11-diketotetranorprosta-13-en-1,16-dioic acid) analogous to PGE<sub>2</sub>-M (which we term PGE<sub>3</sub>-M2) after ingestion of cod liver oil for 4 weeks (Figure 2)<sup>21</sup>. However, reduced sensitivity of the GC/MS method compared with LC/MSx2, lack of an authentic standard and the relatively small quantity of  $\omega$ -3 PUFA administered in this study means that PGE<sub>3</sub>-M2 may have remained undetected. Alternatively, PGE<sub>3</sub> is metabolised to 7 $\alpha$ ,11 $\alpha$ -dihydroxy-5-ketotetranorprosta-9,13-dienoic acid (which we term PGE<sub>3</sub>-M1) in the rat<sup>22</sup>. Therefore, PGE<sub>3</sub>-M1 may be the major metabolite of PGE<sub>3</sub> in humans (U. Diczfalusy – personal communication; Figure 2).

PGE<sub>3</sub>-M1 and PGE<sub>3</sub>-M2 have distinct MS profiles and so can be distinguished by LC/MSx2. Urine from CRC patients taking EPA-FFA 2g daily prior to liver surgery in a randomised controlled trial (ClinicalTrials.gov NCT01070355) will be analysed in order to determine whether one or both PGE<sub>3</sub> metabolites are present in patients predicted to have high baseline levels of PGE-M. A validation set of 10 unblinded urine samples from participants randomised to the EPA-FFA alone group will be analysed by LC/MSx2 in order to confirm that either or both of the PGE<sub>3</sub> metabolites are also detectable in urine from colorectal adenoma patients<sup>23</sup>.

If PGE<sub>3</sub>-M1 and/or PGE<sub>3</sub>-M2 are present in the urine of any seAFOod Trial participant taking EPA-FFA, we will GCLP validate LC/MSx2 quantification of the relevant urinary PGE<sub>3</sub> metabolite. Stability and reproducibility of the analytes will be determined according to BARQA Guidelines, and QC samples will be established prior to simultaneous LC/MSx2 analysis of urine samples for PGE-M and PGE<sub>3</sub>-M1/2.

#### 'Lipidomic' analysis of plasma and mucosal lipid mediators

LC/MSx2 measurement of plasma and tissue COX-dependent eicosanoids relevant to aspirin (PGE<sub>2</sub>, 15R-HETE, 15-epi-LXA<sub>4</sub>) and EPA (PGE<sub>3</sub>, 18R-HEPE, RvE1) is established in the Nicolaou laboratory<sup>10-11</sup>, in collaboration with the Serhan laboratory, which has detected ATLs and RvE1 in ng/ml quantities in plasma from healthy volunteers<sup>6-7</sup>. The LC/MSx2 technique allows simultaneous measurement of multiple lipid analytes in plasma and extracted rectal mucosa against authentic standards available from Cayman Chemical Co.)<sup>11</sup>. Confirmation that relevant lipid mediators are detectable in a pilot set of post-treatment plasma (15R-HETE, 15-epi-LXA<sub>4</sub>, 18R-HEPE, RvE1) and rectal mucosal (PGE<sub>2</sub>, PGE<sub>3</sub>, 15-epi-LXA<sub>4</sub>, RvE1) samples from the first 20 participants randomised to either EPA-FFA or aspirin will prompt GCLP validation of stability and reproducibility of the four most abundant

lipid mediators in seAFOod Trial plasma samples, prior to measurement of these putative lipid biomarkers in pre- and mid-treatment plasma samples from the relevant treatment arms (aspirin; 15R-HETE, 15-epi-LXA4: EPA and EPA/aspirin; 18R-HEPE, RvE1) compared with the placebo alone group. Although, not directly relevant to predictive biomarker validation, measurement of rectal mucosal levels of these lipid mediators (as well as PGE<sub>2</sub> and PGE<sub>3</sub>) will allow a comparison between local (mucosal) and systemic (plasma) levels during the biomarker validation process at the same time as providing important insights into the local mucosal mode of action of aspirin and EPA, alone or in combination. Other studies may develop from these initial experiments including simultaneous measurement of RvE2, if an authentic standard is available.

#### *Immunohistochemistry for COX-2*

Immunohistochemistry on formalin-fixed, paraffin-embedded sections of polypectomy specimens will be performed as described<sup>24</sup>. COX-2 immunoreactivity in epithelial and stromal cell components of adenomas will be scored<sup>24</sup>

#### *Genotype studies*

Genomic (g) DNA will be extracted from leucocytes as described<sup>14</sup>. All gDNA samples will be stored in the central -80°C storage facility in the Institute of Cancer Therapeutics in Bradford. Funding will be sought in order to perform SNP genotype analysis using the latest DNA technology available from 2014 onwards.

#### *Statistical analysis*

Analysis of 10 biomarker variables gives an 'events per variable ratio' of 40, based on an expected total number of events (adenoma recurrence at 12 months as a binary outcome) of approximately 400.

Exploratory analyses of the predictive value of absolute mid-treatment levels of PUFA (EPA, DPA, AA) and lipid mediator (plasma 18R-HEPE, RvE1, 15R-HETE, 15-epi-lipoxin A<sub>4</sub> and urinary PGE-M and PGE<sub>3</sub>-M1/PGE<sub>3</sub>-M2) levels will be performed by derivation of individual odds ratios for an adenoma (total or 'advanced')-free outcome in each treatment arm for biomarker tertiles. Multiple logistic regression will be used to determine the predictive value of these putative biomarkers for adenoma outcomes incorporating known clinical risk factors (eg. adenoma size and histological type) and other factors (eg. EPA dose) as independent co-variables.

Two entirely distinct issues will be addressed in a series of supportive analyses:

1. Treating PUFA and lipid mediator levels as endpoints, we will compare mid- and post-treatment values between treatment arms, to support the hypothesised mechanisms of action of aspirin and EPA.
2. In non-randomised comparisons we will assess the predictive value of (i) absolute mid-treatment biomarker levels, and (ii) the difference between mid- and pre-treatment levels, for adenoma outcomes using our pool of candidate biomarkers and applying modern selection procedures based on AIC to identify a good prediction model.

## References

1. Cuzick J, Otto F, Baron J et al. Aspirin and non-steroidal anti-inflammatory drugs for cancer prevention: an international consensus statement. *Lancet Oncol* 2009;**10**:501-7.
2. Calviello G et al. n-3 polyunsaturated fatty acids and the prevention of colorectal cancer. *Curr Med Chem* 2007;**14**:3059-69.
3. Smith W. Cyclooxygenases, peroxide tone and the allure of fish oil. *Curr Opin Cell Biol* 2005;**17**:174-82.
4. Hull M. Cyclooxygenase-2: How good is it as a target for cancer chemoprevention? *Eur J Cancer* 2005;**41**:1854-63.
5. Hawcroft G, Loadman P, Belluzzi A et al. The effect of the omega-3 polyunsaturated fatty acid eicosapentaenoic acid on E-type prostaglandin synthesis and EP4 receptor signalling in human colorectal cancer cells. *Neoplasia* 2010 (in press).
6. Serhan C, Yacoubian S, Yang R. Anti-inflammatory and proresolving lipid mediators. *Annu Rev Pathol Mech Dis* 2008;**3**:279-312.
7. Arita M, Bianchini F, Aliberti J et al. Stereochemical assignment, anti-inflammatory properties, and receptor for the omega-3 lipid mediator resolvin E1. *J Exp Med* 2005;**201**:713-22.
8. Katan M, Deslypere J, van Birgelen A et al. Kinetics of the incorporation of dietary fatty acids into serum cholesteryl esters, erythrocyte membranes, and adipose tissue: an 18 month controlled study. *J Lipid Res* 1997;**38**:2012-22.
9. West N, Clark S, Phillips R et al. Eicosapentaenoic acid reduces rectal polyp number and size in familial adenomatous polyposis. *Gut* 2010 OnLine First doi 10.1136\_gut.2009.200642.
10. Masoodi M, Nicolaou A. Lipidomic analysis of twenty-seven prostanoids and isoprostanes by liquid chromatography/electrospray tandem mass spectrometry. *Rapid Commun Mass Spectrom* 2006;**20**:3023-9.
11. Masoodi M, Mir A, Petasis N et al. Simultaneous lipidomic analysis of three families of bioactive lipid mediators leukotrienes, resolvins, protectins and related hydroxyl-fatty acids by liquid chromatography/electrospray ionisation tandem mass spectrometry. *Rapid Commun Mass Spectrom* 2008;**22**:75-83.
12. Benamouzig R, Uzzan B, Martin A et al. Cyclooxygenase-2 expression and recurrence of colorectal adenomas: Effect of aspirin chemoprevention. *Gut* 2010;**59**:622-9.
13. Vanamala J, Glagolenko A, Yang P et al. Dietary fish oil and pectin enhance colonocyte apoptosis in part through suppression of PPAR $\cdot$  /PGE<sub>2</sub> and elevation of PGE<sub>3</sub>. *Carcinogenesis* 2008;**29**:790-6.
14. Hubner R, Muir K, Liu J-F et al. Genetic variants of *UGT1A6* influence risk of colorectal adenoma recurrence. *Clin Cancer Res* 2006;**12**:6585-9.
15. Chan A, Tranah G, Giovannucci E et al. Genetic variants in the *UGT1A6* enzyme, aspirin use, and the risk of colorectal adenoma. *J Natl Cancer Inst* 2005;**97**:457-60.
16. Hubner R, Muir K, Liu J-F et al. Ornithine decarboxylase G316A genotype is prognostic for colorectal adenoma recurrence and predicts efficacy of aspirin chemoprevention. *Clin Cancer Res* 2008;**14**:2303-9.
17. Barry E, Sansbury L, Grau M et al. Cyclooxygenase-2 polymorphisms, aspirin treatment, and risk of colorectal adenoma recurrence – Data from a randomized clinical trial. *Cancer Epidemiol Biomarkers Prev* 2009;**18**:2726-33.
18. Fradet V, Cheng I, Casey G et al. Dietary omega-3 fatty acids, cyclooxygenase-2 genetic variation, and aggressive prostate cancer risk. *Clin Cancer Res* 2009;**15**:2559-66.

19. Tanaka T, Shen J, Abecasis G et al. Genome-wide association study of plasma polyunsaturated fatty acids in the InCHIANTI Study. *PLoS Genetics* 2009;**5**;e1000338.
20. Murphey L, Williams M, Sanchez S et al. Quantification of the major urinary metabolite of PGE<sub>2</sub> by a liquid chromatographic/mass spectrometric assay: Determination of cyclooxygenase-specific PGE<sub>2</sub> synthesis in healthy humans and those with lung cancer. *Anal Biochem* 2004;**334**;266-75.
21. Fischer S, von Schacky C, Schweer H. Prostaglandin E<sub>3</sub> and F<sub>3</sub> are excreted in human urine after ingestion of *n*-3 polyunsaturated fatty acids. *Biochim Biophys Acta* 1988;**963**:501-8.
22. Diczfalusy U, Hamberg M. Identification of the major urinary metabolite of prostaglandin E<sub>3</sub> in the rat. *Biochim Biophys Acta* 1986;**878**:387-93.
23. Johnson C, Schmidt C, Shrubsole M et al. Urine PGE-M: A metabolite of prostaglandin E<sub>2</sub> as a potential biomarker of advanced colorectal neoplasia. *Clin Gastroenterol Hepatol* 2006;**4**:1358-65.
24. Chapple K, Cartwright E, Hawcroft G et al. Localisation of cyclooxygenase-2 in human sporadic colorectal adenomas. *Am J Pathol* 2000;**156**:545-53

A) 'western' diet/untreated

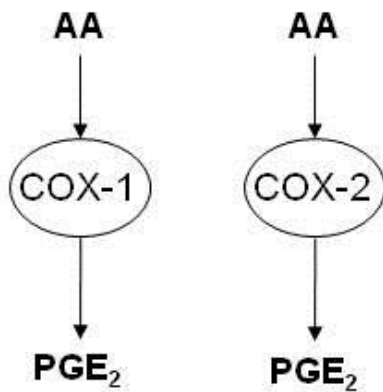

B) 'western' diet/aspirin

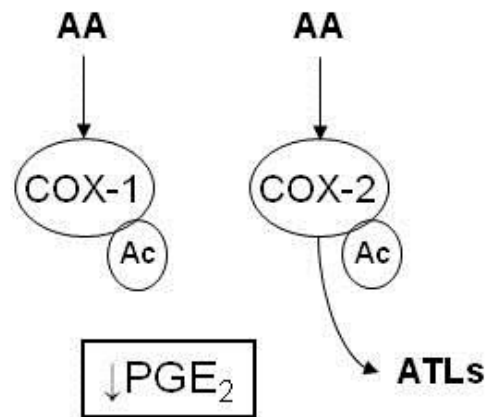

C) dietary/therapeutic EPA

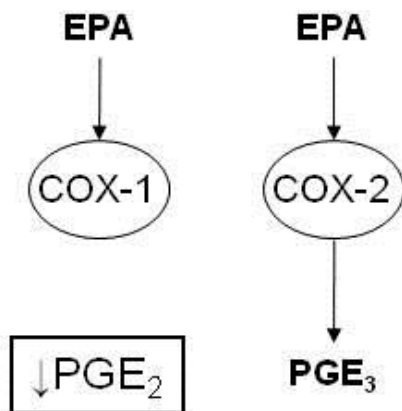

D) EPA + aspirin

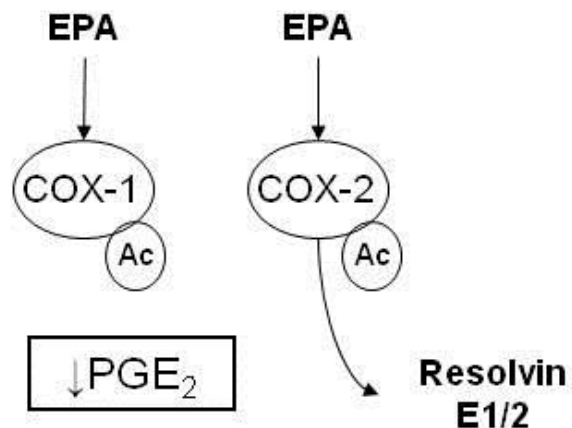

**Figure 1.** Mechanisms of action of aspirin and EPA targeting COX-dependent PGE<sub>2</sub> synthesis. A) In 'western' diets, arachidonic acid (AA) is the predominant substrate for the COX isoforms leading to production of PGE<sub>2</sub>. Both COX-1 and COX-2 play roles in the early stages of intestinal tumorigenesis relevant to CRC chemoprevention. B) Acetylation (Ac) of a conserved serine residue in the COX active site by aspirin inhibits COX-1 entirely but alters activity of COX-2 leading to formation of aspirin-triggered lipoxins (ATLs) in a 5-LOX-dependent manner. The overall result is reduced levels of pro-tumorigenic PGE<sub>2</sub>. C) EPA competes with AA as substrate for both COX enzymes but enzymatic turnover ( $V_{max}$ ) is 10-30 fold lower leading to reduced PGE<sub>2</sub> levels. In addition, EPA drives COX-2-dependent production of equivalent '3-series' PGs such as PGE<sub>3</sub>, which has anti-tumorigenic activity. D) The combination of aspirin and EPA is hypothesised to result in reduced PGE<sub>2</sub> levels but also production of anti-inflammatory E-type resolvins by 5-LOX via the intermediate 18R-HEPE.

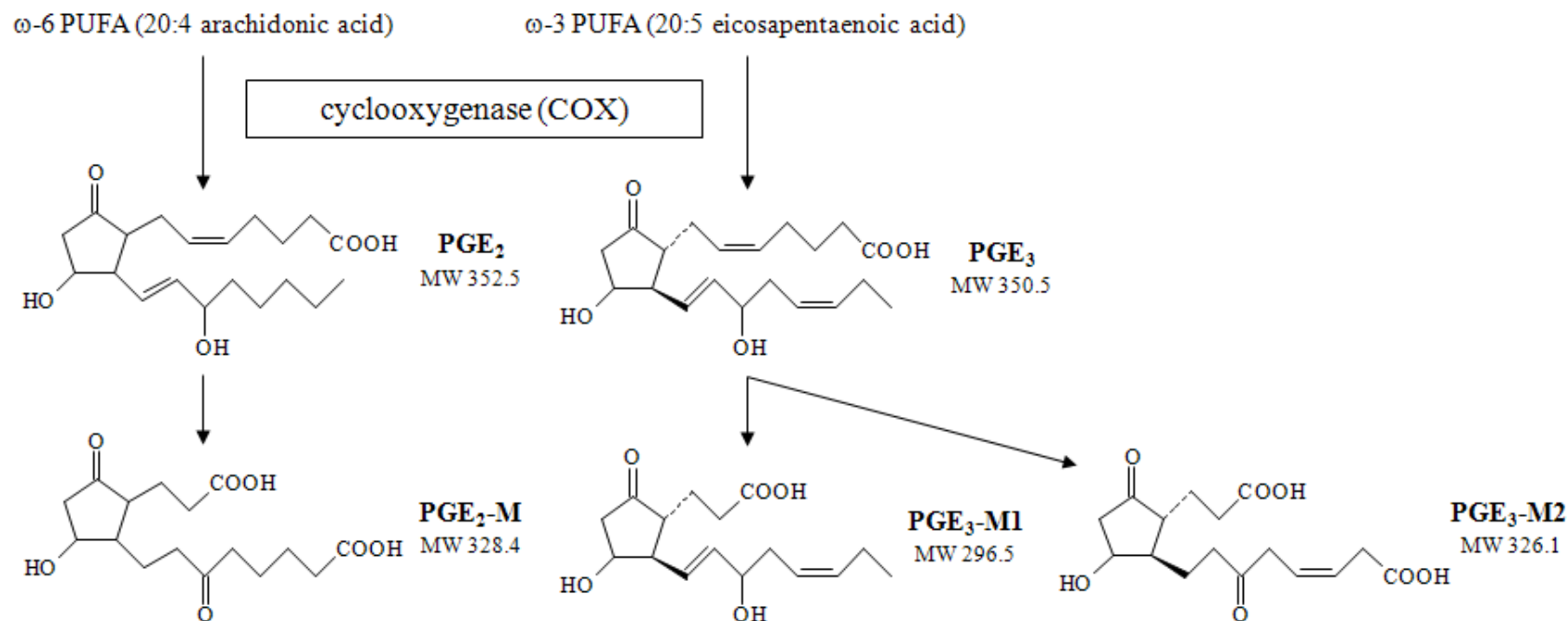

**Figure 2.** Cyclooxygenase-dependent synthesis of PGE<sub>2</sub> or PGE<sub>3</sub> from  $\omega$ -6 or  $\omega$ -3 PUFAs respectively. The predominant urinary metabolite of PGE<sub>2</sub> is PGE<sub>2</sub>-M<sup>20</sup>. It is unclear whether the equivalent metabolite of PGE<sub>3</sub> (PGE<sub>3</sub>-M2) is present in human urine<sup>21</sup>. Studies in the rat suggest that PGE<sub>3</sub>-M1 may be the main urinary metabolite of PGE<sub>3</sub><sup>22</sup>.

## Appendix E: Details of amendments:

### MA01

Page	Section	Previous wording	New wording
4	Abbreviations	<ul style="list-style-type: none"> <li>OTC added as appropriate</li> </ul>	<ul style="list-style-type: none"> <li></li> </ul>
6	Exclusion criteria	<ul style="list-style-type: none"> <li>Regular (&gt;3 doses per week) prescribed aspirin or regular (&gt;3 doses per week) prescribed non-aspirin non-steroidal anti-inflammatory drug (NSAID) use</li> <li>Current or planned regular (&gt;3 doses per week) use of fish oil supplements</li> </ul>	<ul style="list-style-type: none"> <li>Regular (&gt;3 doses per week) prescribed or 'over-the-counter' (OTC) aspirin or regular (&gt;3 doses per week) prescribed or OTC non-aspirin non-steroidal anti-inflammatory drug (NSAID) use*</li> <li>Current or planned regular (&gt;3 doses per week) use of fish oil supplements *</li> </ul> <p>* not an exclusion if self-prescribed and not recommended by a Doctor and willing to stop for the duration of the Trial</p>
18	4.1.2	<ul style="list-style-type: none"> <li>Regular (&gt;3 doses per week) prescribed aspirin or regular (&gt;3 doses per week) prescribed non-aspirin non-steroidal anti-inflammatory drug (NSAID) use</li> <li>Current or planned regular (&gt;3 doses per week) use of fish oil supplements</li> </ul>	<ul style="list-style-type: none"> <li>Regular (&gt;3 doses per week) prescribed or 'over-the-counter' (OTC) aspirin or regular (&gt;3 doses per week) prescribed or OTC non-aspirin non-steroidal anti-inflammatory drug (NSAID) use*</li> <li>Current or planned regular (&gt;3 doses per week) use of fish oil supplements *</li> </ul>
19	4.1.2		<p>* not an exclusion if self-prescribed and not recommended by a Doctor and willing to stop for the duration of the Trial</p>
23	5.4: Storage, dispensing and return	<p>Medications that are prohibited whilst in the trial are warfarin (any dose) or any other anti-coagulant therapy, or any other anti-platelet agent such as clopidogrel, regular (&gt;3 x per week) prescribed aspirin, regular (&gt;3 x per week) prescribed non-steroidal anti-inflammatory drug (NSAID), ongoing or planned use of fish oil supplements and Methotrexate use at a weekly dose of 15 mg or more.</p>	<p>Medications that are prohibited whilst in the trial are warfarin (any dose) or any other anti-coagulant therapy, or any other anti-platelet agent such as clopidogrel, regular (&gt;3 x per week) prescribed or OTC aspirin, regular (&gt;3 x per week) prescribed or OTC non-steroidal anti-inflammatory drug (NSAID), ongoing or planned use of fish oil supplements and Methotrexate use at a weekly dose of 15 mg or more. Please note that participant self-prescription (not on the recommendation of a</p>

			Doctor) of aspirin or another NSAID or a fish oil supplement is not an exclusion if the participant is willing to stop use of aspirin or another NSAID or a fish oil supplement for at least the duration of the Trial.
24	5.6	Methotrexate at a weekly dosage of 15 mg or more, warfarin at any dose or any other anti-coagulant therapy, or any other anti-platelet agent such as clopidogrel, regular (>3 times per week) prescribed any dose aspirin or regular (>3 times per week) prescribed non-aspirin NSAID should not be used during the Trial. If any of these medications are required, the participant should be withdrawn from the Trial.	Methotrexate at a weekly dosage of 15 mg or more, warfarin at any dose or any other anti-coagulant therapy, or any other anti-platelet agent such as clopidogrel, regular (>3 times per week) prescribed or OTC any dose aspirin or regular (>3 times per week) prescribed or OTC non-aspirin NSAID should not be used during the Trial. If any of these medications are required, the participant should be withdrawn from the Trial.